

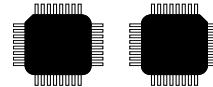

MIMXRT1021CAG4A MIMXRT1021CAF4A

i.MX RT1020 Crossover Processors for Industrial Products



Package Information

Plastic Package

144-Pin LQFP, 20 x 20 mm, 0.5 mm pitch
100-Pin LQFP, 14 x 14 mm, 0.5 mm pitch

Ordering Information

See [Table 2 on page 6](#)

1 i.MX RT1020 introduction

The i.MX RT1020 is a processor of i.MX RT family featuring NXP's advanced implementation of the Arm[®] Cortex[®]-M7 core, which operates at speeds up to 396 MHz to provide high CPU performance and real-time response.

The i.MX RT1020 processor has 256 KB on-chip RAM, which can be flexibly configured as TCM or general-purpose on-chip RAM. The i.MX RT1020 integrates advanced power management module with DCDC and LDO that reduces complexity of external power supply and simplifies power sequencing. The i.MX RT1020 also provides various memory interfaces, including SDRAM, RAW NAND FLASH, NOR FLASH, SD/eMMC, Quad SPI, and a wide range of connectivity interfaces including UART, SPI, I2C, USB, and CAN; for connecting peripherals including WLAN, Bluetooth[™], and GPS. The i.MX RT1020 also has rich audio features, including SPDIF and I2S audio interface. Various analog IP integration, including ADC, analog comparator, temperature sensor, etc.

1. i.MX RT1020 introduction	1
1.1. Features	2
1.2. Ordering information	6
2. Architectural overview	8
2.1. Block diagram	8
3. Modules list	9
3.1. Special signal considerations	15
3.2. Recommended connections for unused analog interfaces	16
4. Electrical characteristics	17
4.1. Chip-level conditions	17
4.2. System power and clocks	24
4.3. I/O parameters	29
4.4. System modules	35
4.5. External memory interface	40
4.6. Audio	50
4.7. Analog	53
4.8. Communication interfaces	60
4.9. Timers	72
5. Boot mode configuration	74
5.1. Boot mode configuration pins	74
5.2. Boot device interface allocation	74
6. Package information and contact assignments	80
6.1. 20 x 20 mm package information	80
6.2. 14 x 14 mm package information	89
7. Revision history	96



The i.MX RT1020 is specifically useful for applications such as:

- Industrial
- Motor Control
- Home Appliance
- IoT

1.1 Features

The i.MX RT1020 processors are based on Arm Cortex-M7 MPCore™ Platform, which has the following features:

- Supports single Arm Cortex-M7 with:
 - 16 KB L1 Instruction Cache
 - 16 KB L1 Data Cache
 - Full featured Floating Point Unit (FPU) with support of the VFPv5 architecture
 - Support the Armv7-M Thumb instruction set
- Integrated MPU, up to 16 individual protection regions
- Up to 256 KB I-TCM and D-TCM in total
- Target frequency of 396 MHz
- Cortex M7 CoreSight™ components integration for debug
- Frequency of the core, as per [Table 11, "Operating ranges," on page 19](#).

The SoC-level memory system consists of the following additional components:

- Boot ROM (96 KB)
- On-chip RAM (256 KB)
 - Configurable RAM size up to 256 KB shared with CM7 TCM
- External memory interfaces:
 - 8/16-bit SDRAM, up to SDRAM-133
 - 8/16-bit SLC NAND FLASH, with ECC handled in software
 - SD/eMMC
 - SPI NOR FLASH
 - Parallel NOR FLASH with XIP support
 - Single/Dual channel Quad SPI FLASH with XIP support
- Timers and PWMs:
 - Two General Programmable Timers
 - 4-channel generic 32-bit resolution timer
 - Each support standard capture and compare operation
 - Four Periodical Interrupt Timers
 - Generic 32-bit resolution timer
 - Periodical interrupt generation

- Two Quad Timers
 - 4-channel generic 16-bit resolution timer each
 - Each support standard capture and compare operation
 - Quadrature decoder integrated
- Two FlexPWMs
 - Up to 12 individual PWM channels per each
 - 16-bit resolution PWM suitable for Motor Control applications
- Two Quadrature Encoders/Decoders

Each i.MX RT1020 processor enables the following interfaces to external devices (some of them are muxed and not available simultaneously):

- Audio:
 - S/PDIF input and output
 - Three synchronous audio interface (SAI) modules supporting I2S, AC97, TDM, and codec/DSP interfaces
 - MQS interface for medium quality audio via GPIO pads
- Connectivity:
 - One USB 2.0 OTG controller with integrated PHY interface
 - Two Ultra Secure Digital Host Controller (uSDHC) interfaces
 - MMC 4.5 compliance support up to 100 MB/sec
 - SD/SDIO 3.0 compliance with 200 MHz SDR signaling to support up to 100 MB/sec
 - Support for SDXC (extended capacity)
 - One 10/100 M Ethernet controller with IEEE1588 supported
 - Eight universal asynchronous receiver/transmitter (UARTs) modules
 - Four I2C modules
 - Four SPI modules
 - Two FlexCAN modules
- GPIO and Pin Multiplexing:
 - General-purpose input/output (GPIO) modules with interrupt capability
 - Input/output multiplexing controller (IOMUXC) to provide centralized pad control
 - 96 GPIOs for 144-pin LQFP package, 57 GPIOs for 100-pin LQFP package
 - One FlexIO

The i.MX RT1020 processors integrate Analog module:

- Two Analog-Digital-Converters (ADC), one of which supports differential inputs, up to 19 channels
- Four Analog Comparators (ACMP)

The i.MX RT1020 processors integrate advanced power management unit and controllers:

- Full PMIC integration, including on-chip DCDC and LDOs
- Temperature sensor with programmable trip points

i.MX RT1020 introduction

- GPC hardware power management controller

The i.MX RT1020 processors support the following system debug:

- Arm CortexM7 CoreSight debug and trace architecture
- Trace Port Interface Unit (TPIU) to support off-chip real-time trace
- Support for 5-pin (JTAG) and SWD debug interfaces selected by eFuse

Security functions are enabled and accelerated by the following hardware:

- High Assurance Boot (HAB)
- Data Co-Processor (DCP):
 - AES-128, ECB, and CBC mode
 - SHA-1 and SHA-256
 - CRC-32
- Bus Encryption Engine (BEE)
 - AES-128, ECB, and CTR mode
 - On-the-fly QSPI Flash decryption
- True random number generation (TRNG)
- Secure Non-Volatile Storage (SNVS)
 - Secure real-time clock (RTC)
 - Zero Master Key (ZMK)
- Secure JTAG Controller (SJC)

Table 1 demonstrates the comparison between 100 LQFP and 144 LQFP package.

Table 1. The comparison between 100 LQFP and 144 LQFP package

	144 LQFP	100 LQFP
RAM/KB	256	256
USB OTG	1	1
ENET port	MII/RMII	RMII
KPP number	8 x 8	4 x 4
SEMC	Yes	No
SPDIF	Yes	Yes
uSDHC ¹	2	1
FlexIO	32	22
GPIO	96	57
FlexPWM Channel	24	16
XBAR IN/OUT	16	9
SAI	3	3

Table 1. The comparison between 100 LQFP and 144 LQFP package (continued)

	144 LQFP	100 LQFP
ACMP	4	4
ADC channel	19	10
FLEXCAN	2	2
I2C	4	4
LPUART	8	8
FlexSPI	1	1
LPSPI	4	4

¹ SD is 3.3 V in the 100 LQFP package, while it supports both 3.3 V and 1.8 V in the 144 LQFP package.

The actual feature set depends on the part numbers as described in [Table 2](#). Functions such as display and camera interfaces, connectivity interfaces, and security features are not offered on all derivatives.

1.2 Ordering information

Table 2 provides examples of orderable part numbers covered by this data sheet.

Table 2. Ordering information

Part Number	Feature	Package	Junction Temperature T _j (°C)
MIMXRT1021CAG4A	Features supports: <ul style="list-style-type: none"> • 396 MHz, industrial grade for general purpose • 256K RAM • CAN x2 • Ethernet • eMMC 4.5/SD 3.0 x2 • USB OTG x1 • SAI x3 • SPDIF x1 • Timer x2 • PWM x2 • UART x8 • I²C x4 • SPI x4 • ADC x2 • ACMP x4 • 96 GPIOs 	20 x 20 mm, 0.5 mm pitch, 144-pin LQFP	-40 to +105
MIMXRT1021CAF4A	Features supports: <ul style="list-style-type: none"> • 396 MHz, industrial grade for general purpose • 256K RAM • CAN x2 • Ethernet • eMMC 4.5/SD 3.0 x1 • USB OTG x1 • SAI x3 • SPDIF x1 • Timer x2 • PWM x2 • UART x8 • I²C x4 • SPI x4 • ADC x2 • ACMP x4 • 57 GPIOs 	14 x 14 mm, 0.5 mm pitch, 100-pin LQFP	-40 to +105

Figure 1 describes the part number nomenclature so that characteristics of a specific part number can be identified (for example, cores, frequency, temperature grade, fuse options, and silicon revision). The primary characteristic which describes which data sheet applies to a specific part is the temperature grade (junction) field.

Ensure to have the proper data sheet for specific part by verifying the temperature grade (junction) field and matching it to the proper data sheet. If there are any questions, visit the web page nxp.com/IMXRT or contact an NXP representative for details.

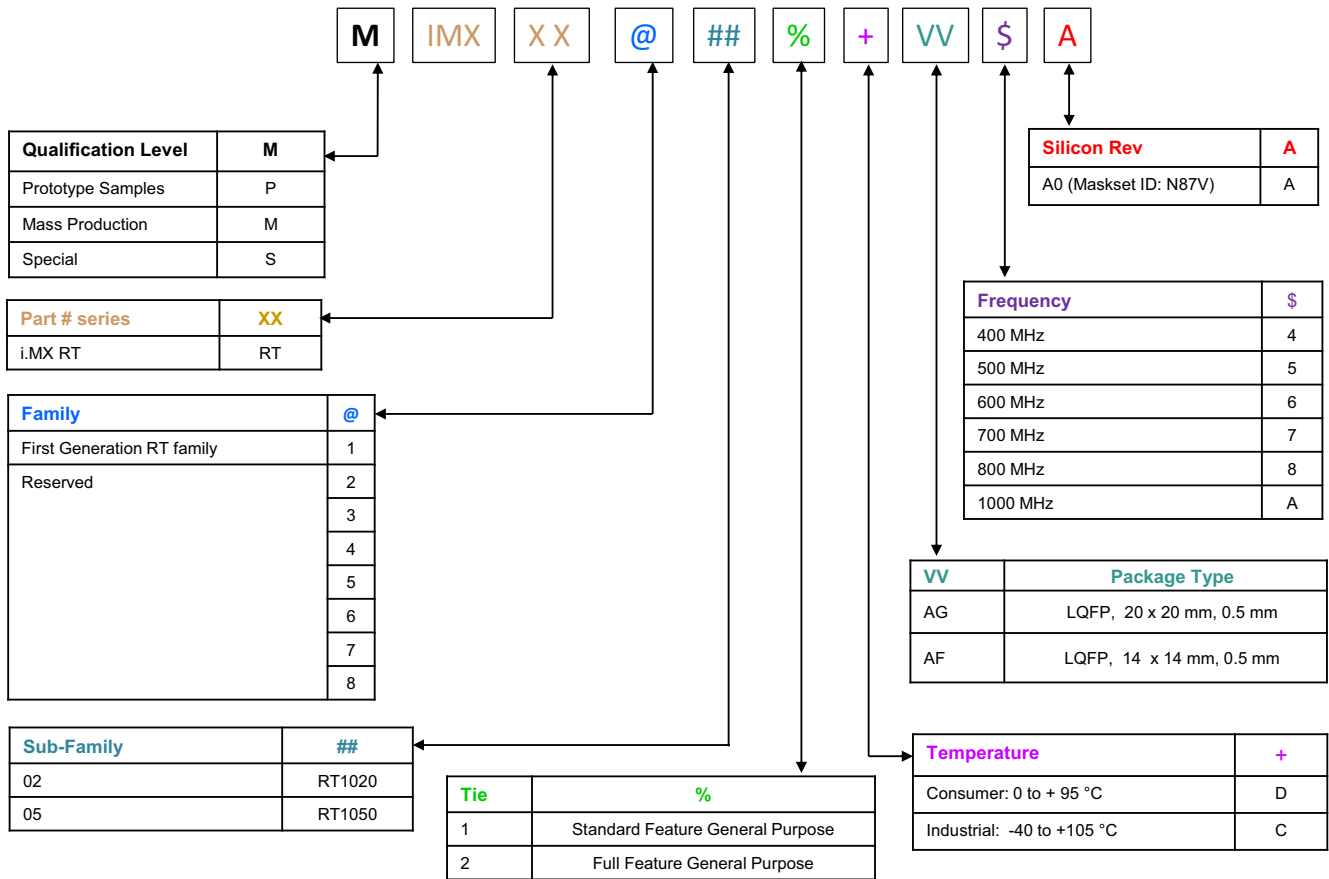

Figure 1. Part number nomenclature—i.MX RT1020

2 Architectural overview

The following subsections provide an architectural overview of the i.MX RT1020 processor system.

2.1 Block diagram

Figure 2 shows the functional modules in the i.MX RT1020 processor system¹.

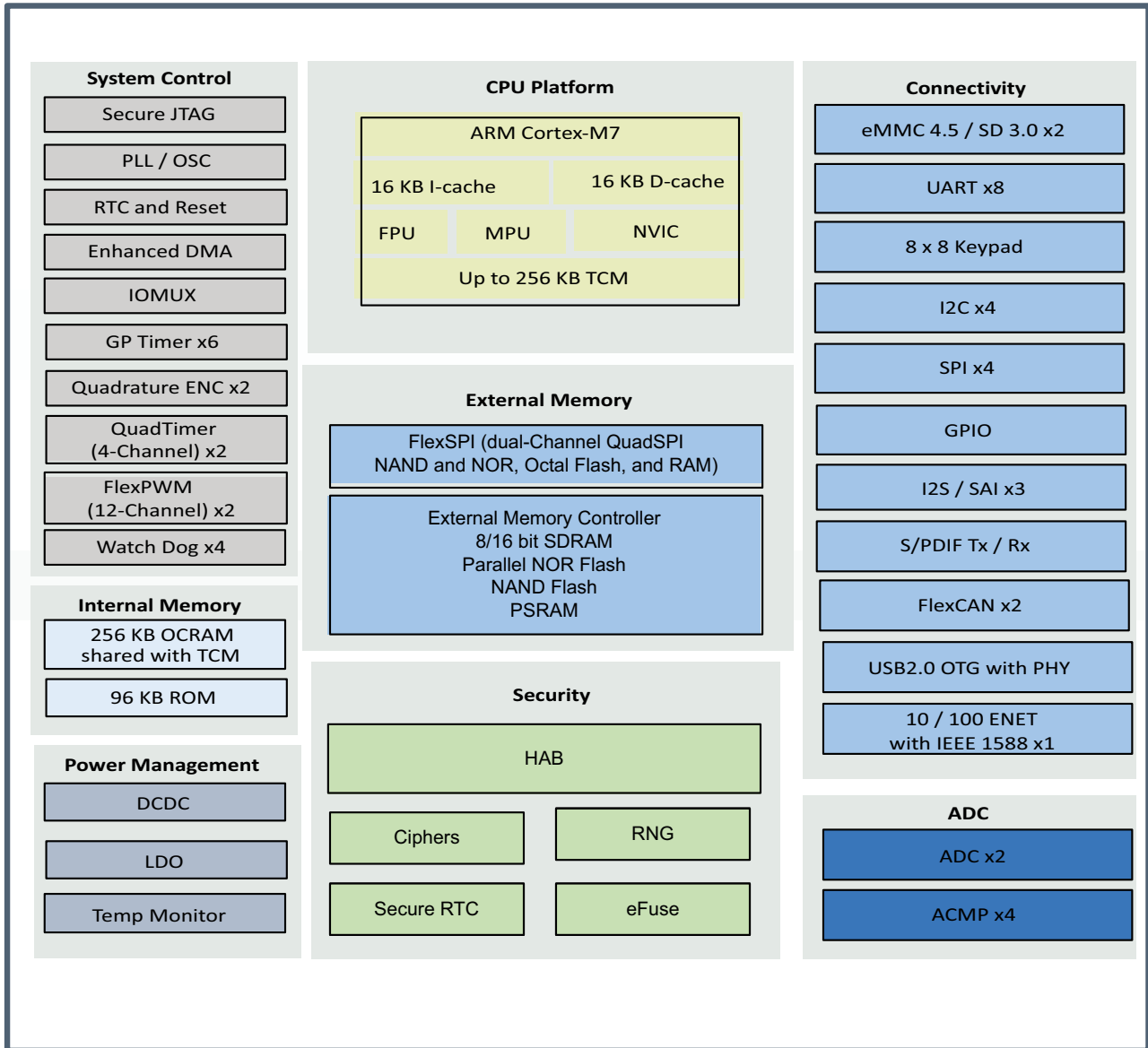

Figure 2. i.MX RT1020 system block diagram

1. Some modules shown in this block diagram are not offered on all derivatives. See Table 2 for details.

3 Modules list

The i.MX RT1020 processors contain a variety of digital and analog modules. [Table 3](#) describes these modules in alphabetical order.

Table 3. i.MX RT1020 modules list

Block mnemonic	Block name	Subsystem	Brief description
ACMP1 ACMP2 ACMP3 ACMP4	Analog Comparator	Analog	The comparator (CMP) provides a circuit for comparing two analog input voltages. The comparator circuit is designed to operate across the full range of the supply voltage (rail-to-rail operation).
ADC1 ADC2	Analog to Digital Converter	Analog	The ADC is a 12-bit general purpose analog to digital converter.
AOI	And-Or-Inverter	Cross Trigger	The AOI provides a universal boolean function generator using a four term sum of products expression with each product term containing true or complement values of the four selected inputs (A, B, C, D).
Arm	Arm Platform	Arm	The Arm Core Platform includes 1x Cortex-M7 core. It also includes associated sub-blocks, such as Nested Vectored Interrupt Controller (NVIC), Floating-Point Unit (FPU), Memory Protection Unit (MPU), and CoreSight debug modules.
BEE	Bus Encryption Engine	Security	On-The-Fly FlexSPI Flash Decryption
CCM GPC SRC	Clock Control Module, General Power Controller, System Reset Controller	Clocks, Resets, and Power Control	These modules are responsible for clock and reset distribution in the system, and also for the system power management.
CSU	Central Security Unit	Security	The Central Security Unit (CSU) is responsible for setting comprehensive security policy within the i.MX RT1020 platform.
DAP	Debug Access Port	System Control Peripherals	The DAP provides real-time access for the debugger without halting the core to: <ul style="list-style-type: none"> • System memory and peripheral registers • All debug configuration registers The DAP also provides debugger access to JTAG scan chains. The DAP module is internal to the Cortex-M7 Core Platform.
DCDC	DCDC Converter	Analog	The DCDC module is used for generating power supply for core logic. Main features are: <ul style="list-style-type: none"> • Adjustable high efficiency regulator • Supports 3.3 V input voltage • Supports nominal run and low power standby modes • Supports at 0.9 ~ 1.3 V output in run mode • Supports at 0.9 ~ 1.0 V output in standby mode • Over current and over voltage detection

Table 3. i.MX RT1020 modules list (continued)

Block mnemonic	Block name	Subsystem	Brief description
eDMA	enhanced Direct Memory Access	System Control Peripherals	There is an enhanced DMA (eDMA) engine and two DMA_MUX. <ul style="list-style-type: none"> The eDMA is a 32 channel DMA engine, which is capable of performing complex data transfers with minimal intervention from a host processor. The DMA_MUX is capable of multiplexing up to 128 DMA request sources to the 32 DMA channels of eDMA.
ENC	Quadrature Encoder/Decoder	Timer Peripherals	The enhanced quadrature encoder/decoder module provides interfacing capability to position/speed sensors. There are five input signals: PHASEA, PHASEB, INDEX, TRIGGER, and HOME. This module is used to decode shaft position, revolution count, and speed.
ENET	Ethernet Controller	Connectivity Peripherals	The Ethernet Media Access Controller (MAC) is designed to support 10/100 Mbit/s Ethernet/IEEE 802.3 networks. An external transceiver interface and transceiver function are required to complete the interface to the media. The module has dedicated hardware to support the IEEE 1588 standard. See the ENET chapter of the reference manual for details.
EWM	External Watchdog Monitor	Timer Peripherals	The EWM modules is designed to monitor external circuits, as well as the software flow. This provides a back-up mechanism to the internal WDOG that can reset the system. The EWM differs from the internal WDOG in that it does not reset the system. The EWM, if allowed to time-out, provides an independent trigger pin that when asserted resets or places an external circuit into a safe mode.
FLEXCAN1 FLEXCAN2	Flexible Controller Area Network	Connectivity Peripherals	The CAN protocol was primarily, but not only, designed to be used as a vehicle serial data bus, meeting the specific requirements of this field: real-time processing, reliable operation in the Electromagnetic interference (EMI) environment of a vehicle, cost-effectiveness and required bandwidth. The FlexCAN module is a full implementation of the CAN protocol specification, Version 2.0 B, which supports both standard and extended message frames.
FlexIO1	Flexible Input/output	Connectivity and Communications	The FlexIO is capable of supporting a wide range of protocols including, but not limited to: UART, I2C, SPI, I2S, camera interface, display interface, PWM waveform generation, etc. The module can remain functional when the chip is in a low power mode provided the clock it is using remain active.

Table 3. i.MX RT1020 modules list (continued)

Block mnemonic	Block name	Subsystem	Brief description
FlexPWM1 FlexPWM2	Pulse Width Modulation	Timer Peripherals	The pulse-width modulator (PWM) contains four PWM sub-modules, each of which is set up to control a single half-bridge power stage. Fault channel support is provided. The PWM module can generate various switching patterns, including highly sophisticated waveforms.
FlexRAM	RAM	Memories	The i.MX RT1020 has 256 KB of on-chip RAM which could be flexible allocated to I-TCM, D-TCM, and on-chip RAM (OCRAM) in a 32 KB granularity. The FlexRAM is the manager of the 256 KB on-chip RAM array. Major functions of this blocks are: interfacing to I-TCM and D-TCM of Arm core and OCRAM controller; dynamic RAM arrays allocation for I-TCM, D-TCM, and OCRAM.
FlexSPI	Quad Serial Peripheral Interface	Connectivity and Communications	FlexSPI acts as an interface to one or two external serial flash devices, each with up to four bidirectional data lines.
GPIO1 GPIO2 GPIO3 GPIO5	General Purpose I/O Modules	System Control Peripherals	Used for general purpose input/output to external ICs. Each GPIO module supports up to 32 bits of I/O.
GPT1 GPT2	General Purpose Timer	Timer Peripherals	Each GPT is a 32-bit “free-running” or “set and forget” mode timer with programmable prescaler and compare and capture register. A timer counter value can be captured using an external event and can be configured to trigger a capture event on either the leading or trailing edges of an input pulse. When the timer is configured to operate in “set and forget” mode, it is capable of providing precise interrupts at regular intervals with minimal processor intervention. The counter has output compare logic to provide the status and interrupt at comparison. This timer can be configured to run either on an external clock or on an internal clock.
KPP	Keypad Port	Human Machine Interfaces	The KPP is a 16-bit peripheral that can be used as a keypad matrix interface or as general purpose input/output (I/O). It supports 8 x 8 external key pad matrix. Main features are: <ul style="list-style-type: none"> • Multiple-key detection • Long key-press detection • Standby key-press detection • Supports a 2-point and 3-point contact key matrix
LPI2C1 LPI2C2 LPI2C3 LPI2C4	Low Power Inter-integrated Circuit	Connectivity and Communications	The LPI2C is a low power Inter-Integrated Circuit (I2C) module that supports an efficient interface to an I2C bus as a master. The I2C provides a method of communication between a number of external devices. More detailed information, see Section 4.8.2, LPI2C module timing parameters .

Table 3. i.MX RT1020 modules list (continued)

Block mnemonic	Block name	Subsystem	Brief description
LPSP11 LPSP12 LPSP13 LPSP14	Low Power Serial Peripheral Interface	Connectivity and Communications	The LPSPI is a low power Serial Peripheral Interface (SPI) module that support an efficient interface to an SPI bus as a master and/or a slave. <ul style="list-style-type: none"> • It can continue operating while the chip is in stop modes, if an appropriate clock is available • Designed for low CPU overhead, with DMA off loading of FIFO register access
LPUART1 LPUART2 LPUART3 LPUART4 LPUART5 LPUART6 LPUART7 LPUART8	UART Interface	Connectivity Peripherals	Each of the UART modules support the following serial data transmit/receive protocols and configurations: <ul style="list-style-type: none"> • 7- or 8-bit data words, 1 or 2 stop bits, programmable parity (even, odd or none) • Programmable baud rates up to 5 Mbps.
MQS	Medium Quality Sound	Multimedia Peripherals	MQS is used to generate 2-channel medium quality PWM-like audio via two standard digital GPIO pins.
QuadTimer1 QuadTimer2	QuadTimer	Timer Peripherals	The quad-timer provides four time channels with a variety of controls affecting both individual and multi-channel features. Specific features include up/down count, cascading of counters, programmable module, count once/repeated, counter preload, compare registers with preload, shared use of input signals, prescaler controls, independent capture/compare, fault input control, programmable input filters, and multi-channel synchronization.
ROMCP	ROM Controller with Patch	Memories and Memory Controllers	The ROMCP acts as an interface between the Arm advanced high-performance bus and the ROM. The on-chip ROM is only used by the Cortex-M7 core during boot up. Size of the ROM is 96 KB.
RTC OSC	Real Time Clock Oscillator	Clock Sources and Control	The RTC OSC provides the clock source for the Real-Time Clock module. The RTC OSC module, in conjunction with an external crystal, generates a 32.678 kHz reference clock for the RTC.
RTWDOG	Watch Dog	Timer Peripherals	The RTWDG module is a high reliability independent timer that is available for system to use. It provides a safety feature to ensure software is executing as planned and the CPU is not stuck in an infinite loop or executing unintended code. If the WDOG module is not serviced (refreshed) within a certain period, it resets the MCU. Windowed refresh mode is supported as well.
SAI1 SAI2 SAI3	Synchronous Audio Interface	Multimedia Peripherals	The SAI module provides a synchronous audio interface (SAI) that supports full duplex serial interfaces with frame synchronization, such as I2S, AC97, TDM, and codec/DSP interfaces.
SA-TRNG	Standalone True Random Number Generator	Security	The SA-TRNG is hardware accelerator that generates a 512-bit entropy as needed by an entropy consuming module or by other post processing functions.

Table 3. i.MX RT1020 modules list (continued)

Block mnemonic	Block name	Subsystem	Brief description
SEMC	Smart External Memory Controller	Memory and Memory Controller	The SEMC is a multi-standard memory controller optimized for both high-performance and low pin-count. It can support multiple external memories in the same application with shared address and data pins. The interface supported includes SDRAM, NOR Flash, SRAM, and NAND Flash, as well as 8080 display interface.
SJC	System JTAG Controller	System Control Peripherals	The SJC provides JTAG interface, which complies with JTAG TAP standards, to internal logic. The i.MX RT1020 processors use JTAG port for production, testing, and system debugging. In addition, the SJC provides BSR (Boundary Scan Register) standard support, which complies with IEEE1149.1 and IEEE1149.6 standards. The JTAG port is accessible during platform initial laboratory bring-up, for manufacturing tests and troubleshooting, as well as for software debugging by authorized entities. The i.MX RT1020 SJC incorporates three security modes for protecting against unauthorized accesses. Modes are selected through eFUSE configuration.
SNVS	Secure Non-Volatile Storage	Security	Secure Non-Volatile Storage, including Secure Real Time Clock, Security State Machine, and Master Key Control.
SPDIF	Sony Philips Digital Interconnect Format	Multimedia Peripherals	A standard audio file transfer format, developed jointly by the Sony and Phillips corporations. Has Transmitter and Receiver functionality.
Temp Monitor	Temperature Monitor	Analog	The temperature sensor implements a temperature sensor/conversion function based on a temperature-dependent voltage to time conversion.
USBO2	Universal Serial Bus 2.0	Connectivity Peripherals	USBO2 (USB OTG1) contains: <ul style="list-style-type: none"> • One high-speed OTG 2.0 module with integrated HS USB PHY • Support eight Transmit (TX) and eight Receive (Rx) endpoints, including endpoint 0

Table 3. i.MX RT1020 modules list (continued)

Block mnemonic	Block name	Subsystem	Brief description
uSDHC1 uSDHC2	SD/MMC and SDXC Enhanced Multi-Media Card / Secure Digital Host Controller	Connectivity Peripherals	<p>i.MX RT1020 specific SoC characteristics: All four MMC/SD/SDIO controller IPs are identical and are based on the uSDHC IP. They are:</p> <ul style="list-style-type: none"> • Fully compliant with MMC command/response sets and Physical Layer as defined in the Multimedia Card System Specification, v4.5/4.2/4.3/4.4/4.41/ including high-capacity (size > 2 GB) cards HC MMC. • Fully compliant with SD command/response sets and Physical Layer as defined in the SD Memory Card Specifications, v3.0 including high-capacity SDXC cards up to 2 TB. • Fully compliant with SDIO command/response sets and interrupt/read-wait mode as defined in the SDIO Card Specification, Part E1, v3.0 <p>Two ports support:</p> <ul style="list-style-type: none"> • 1-bit or 4-bit transfer mode specifications for SD and SDIO cards up to UHS-I SDR104 mode (104 MB/s max) • 1-bit, 4-bit, or 8-bit transfer mode specifications for MMC cards up to 52 MHz in both SDR and DDR modes (104 MB/s max) • 4-bit transfer mode specifications for eMMC chips up to 100 MHz in HS200 mode (100 MB/s max)
WDOG1 WDOG2	Watch Dog	Timer Peripherals	The Watch Dog Timer supports two comparison points during each counting period. Each of the comparison points is configurable to evoke an interrupt to the Arm core, and a second point evokes an external event on the WDOG line.
XBAR	Cross BAR	Cross Trigger	Each crossbar switch is an array of muxes with shared inputs. Each mux output provides one output of the crossbar. The number of inputs and the number of muxes/outputs are user configurable and registers are provided to select which of the shared inputs are routed to each output.

3.1 Special signal considerations

Table 4 lists special signal considerations for the i.MX RT1020 processors. The signal names are listed in alphabetical order.

The package contact assignments can be found in [Section 6, Package information and contact assignments](#). Signal descriptions are provided in the *i.MX RT1020 Reference Manual (IMXRT1020RM)*.

Table 4. Special signal considerations

Signal name	Remarks
DCDC_PSWITCH	PAD is in DCDC_IN domain and connected the ground to bypass DCDC. To enable DCDC function, assert to DCDC_IN with at least 1ms delay for DCDC_IN rising edge.
RTC_XTALI/RTC_XTALO	If the user wishes to configure RTC_XTALI and RTC_XTALO as an RTC oscillator, a 32.768 kHz crystal, (≤ 100 k Ω ESR, 10 pF load) should be connected between RTC_XTALI and RTC_XTALO. Keep in mind the capacitors implemented on either side of the crystal are about twice the crystal load capacitor. To hit the exact oscillation frequency, the board capacitors need to be reduced to account for board and chip parasitics. The integrated oscillation amplifier is self biasing, but relatively weak. Care must be taken to limit parasitic leakage from RTC_XTALI and RTC_XTALO to either power or ground (>100 M Ω). This will debias the amplifier and cause a reduction of startup margin. Typically RTC_XTALI and RTC_XTALO should bias to approximately 0.5 V. If it is desired to feed an external low frequency clock into RTC_XTALI the RTC_XTALO pin must remain unconnected or driven with a complimentary signal. The logic level of this forcing clock should not exceed VDD_SNVS_CAP level and the frequency should be <100 kHz under typical conditions. In case when high accuracy real time clock are not required system may use internal low frequency ring oscillator. It is recommended to connect RTC_XTALI to GND and keep RTC_XTALO unconnected.
XTALI/XTALO	A 24.0 MHz crystal should be connected between XTALI and XTALO. External load capacitance value depends on the typical load capacitance of crystal used and PCB design. The crystal must be rated for a maximum drive level of 250 μ W. An ESR (equivalent series resistance) of typical 80 Ω is recommended. NXP SDK software requires 24 MHz on XTALI/XTALO. The crystal can be eliminated if an external 24 MHz oscillator is available in the system. In this case, XTALO must be directly driven by the external oscillator and XTALI mounted with 18 pF capacitor. The logic level of this forcing clock cannot exceed NVCC_PLL level. If this clock is used as a reference for USB, then there are strict frequency tolerance and jitter requirements. See OSC24M chapter and relevant interface specifications chapters for details.
GPANAIO	This signal is reserved for NXP manufacturing use only. This output must remain unconnected.
JTAG_#####	The JTAG interface is summarized in Table 5 . Use of external resistors is unnecessary. However, if external resistors are used, the user must ensure that the on-chip pull-up/down configuration is followed. For example, do not use an external pull down on an input that has on-chip pull-up. JTAG_TDO is configured with a keeper circuit such that the non-connected condition is eliminated if an external pull resistor is not present. An external pull resistor on JTAG_TDO is detrimental and should be avoided. JTAG_MOD is referenced as SJC_MOD in the i.MX RT1020 reference manual. Both names refer to the same signal. JTAG_MOD must be externally connected to GND for normal operation. Termination to GND through an external pull-down resistor (such as 1 k Ω) is allowed. JTAG_MOD set to hi configures the JTAG interface to mode compliant with IEEE1149.1 standard. JTAG_MOD set to low configures the JTAG interface for common SW debug adding all the system TAPs to the chain.
NC	These signals are No Connect (NC) and should be disconnected by the user.

Table 4. Special signal considerations (continued)

Signal name	Remarks
POR_B	This cold reset negative logic input resets all modules and logic in the IC. May be used in addition to internally generated power on reset signal (logical AND, both internal and external signals are considered active low).
ONOFF	ONOFF can be configured in debounce, off to on time, and max time-out configurations. The debounce and off to on time configurations supports 0, 50, 100 and 500 ms. Debounce is used to generate the power off interrupt. While in the ON state, if ONOFF button is pressed longer than the debounce time, the power off interrupt is generated. Off to on time supports the time it takes to request power on after a configured button press time has been reached. While in the OFF state, if ONOFF button is pressed longer than the off to on time, the state will transition from OFF to ON. Max time-out configuration supports 5, 10, 15 seconds and disable. Max time-out configuration supports the time it takes to request power down after ONOFF button has been pressed for the defined time.
TEST_MODE	TEST_MODE is for NXP factory use. The user must tie this pin directly to GND.
WAKEUP	A GPIO powered by SNVS domain power supply which can be configured as wakeup source in SNVS mode.

Table 5. JTAG controller interface summary

JTAG	I/O type	On-chip termination
JTAG_TCK	Input	100 kΩ pull-down
JTAG_TMS	Input	47 kΩ pull-up
JTAG_TDI	Input	47 kΩ pull-up
JTAG_TDO	3-state output	Keeper
JTAG_TRSTB	Input	47 kΩ pull-up
JTAG_MOD	Input	100 kΩ pull-down

3.2 Recommended connections for unused analog interfaces

Table 6 shows the recommended connections for unused analog interfaces.

Table 6. Recommended connections for unused analog interfaces

Module	Pad name	Recommendations if unused
USB	USB_OTG1_CHD_B, USB_OTG1_DN, USB_OTG1_DP, USB_OTG1_VBUS	Not connected
ADC	VDDA_ADC_3P3	VDDA_ADC_3P3 must be powered even if the ADC is not used.

4 Electrical characteristics

This section provides the device and module-level electrical characteristics for the i.MX RT1020 processors.

4.1 Chip-level conditions

This section provides the device-level electrical characteristics for the IC. See [Table 7](#) for a quick reference to the individual tables and sections.

Table 7. i.MX RT1020 chip-Level conditions

For these characteristics	Topic appears
Absolute maximum ratings	on page 17
Thermal resistance	on page 18
Operating ranges	on page 19
External clock sources	on page 21
Maximum supply currents	on page 22
Low power mode supply currents	on page 23
USB PHY current consumption	on page 23

4.1.1 Absolute maximum ratings

CAUTION

Stress beyond those listed under [Table 8](#) may cause permanent damage to the device. These are stress ratings only. Functional operation of the device at these or any other conditions beyond those indicated under “recommended operating conditions” is not implied. Exposure to absolute-maximum-rated conditions for extended periods may affect device reliability.

[Table 8](#) shows the absolute maximum operating ratings.

Table 8. Absolute maximum ratings

Parameter Description	Symbol	Min	Max	Unit
Core supplies input voltage	VDD_SOC_IN	-0.3	1.6	V
VDD_HIGH_IN supply voltage	VDD_HIGH_IN	-0.3	3.7	V
Power for DCDC	DCDC_IN	-0.3	3.6	V
Supply input voltage to Secure Non-Volatile Storage and Real Time Clock	VDD_SNVS_IN	-0.3	3.6	V
USB VBUS supply	USB_OTG1_VBUS	—	5.5	V
Supply for 12-bit ADC	VDDA_ADC	3	3.6	V

Electrical characteristics

Table 8. Absolute maximum ratings (continued)

IO supply for GPIO in SDIO1 bank (3.3 V mode)	NVCC_SD0	3	3.6	V
IO supply for GPIO in SDIO1 bank (1.8 V mode)		1.65	1.95	V
IO supply for GPIO bank (3.3 V mode)	NVCC_GPIO	3	3.6	V
ESD Damage Immunity:	Vesd			
Human Body Model (HBM) Charge Device Model (CDM)		— —	1000 500	V
Input/Output Voltage range	V _{in/Vout}	-0.5	OVDD + 0.3 ¹	V
Storage Temperature range	T _{STORAGE}	-40	150	°C

¹ OVDD is the I/O supply voltage.

4.1.2 Thermal resistance

Following sections provide the thermal resistance data.

4.1.2.1 20 x 20 mm package thermal resistance

Table 9 displays the 20 x 20 mm LQFP package thermal resistance data.

Table 9. 20 x 20 mm package thermal resistance data

Rating	Board type	Symbol	Value	Unit	
Junction to Ambient Natural convection	Single-layer board (1s)	R _{θJA}	62	°C/W	1,2
Junction to Ambient Natural convection	Four-layer board (2s2p)	R _{θJA}	52	°C/W	1,2
Junction to Ambient (@200 ft/min)	Single layer board (1s)	R _{θJMA}	53	°C/W	1,3
Junction to Ambient (@200 ft/min)	Four layer board (2s2p)	R _{θJMA}	46	°C/W	1,3
Junction to Board	—	R _{θJB}	41	°C/W	4
Junction to Case	—	R _{θJC}	19	°C/W	5
Junction to Package Top	Natural Convection	Ψ _{JT}	3	°C/W	6

¹ Junction temperature is a function of die size, on-chip power dissipation, package thermal resistance, mounting site (board) temperature, ambient temperature, air flow, power dissipation of other components on the board, and board thermal resistance.

² Per JEDEC JESD51-2 with natural convection for horizontally oriented board. Board meets JESD51-9 specification for 1s or 2s2p board, respectively.

³ Per JEDEC JESD51-6 with forced convection for horizontally oriented board. Board meets JESD51-9 specification for 1s or 2s2p board, respectively.

⁴ Thermal resistance between the die and the printed circuit board per JEDEC JESD51-8. Board temperature is measured on the top surface of the board near the package.

⁵ Thermal resistance between the die and the case top surface as measured by the cold plate method (MIL SPEC-883 Method 1012.1).

⁶ Thermal characterization parameter indicating the temperature difference between package top and the junction temperature per JEDEC JESD51-2. When Greek letters are not available, the thermal characterization parameter is written as Psi-JT.

4.1.2.2 14 x 14 mm package thermal resistance

Table 9 displays the 14 x 14 mm LQFP package thermal resistance data.

Table 10. 14 x 14 mm package thermal resistance data

Rating	Test Conditions	Symbol	Value	Unit	Notes
Junction to Ambient Natural convection	Single-layer board (1s)	$R_{\theta JA}$	63	°C/W	1,2
Junction to Ambient Natural convection	Four-layer board (2s2p)	$R_{\theta JA}$	52	°C/W	1,2
Junction to Ambient (@200 ft/min)	Single layer board (1s)	$R_{\theta JMA}$	53	°C/W	1,3
Junction to Ambient (@200 ft/min)	Four layer board (2s2p)	$R_{\theta JMA}$	46	°C/W	1,3
Junction to Board	—	$R_{\theta JB}$	36	°C/W	4
Junction to Case	—	$R_{\theta JC}$	19	°C/W	5
Junction to Package Top	Natural Convection	Ψ_{JT}	3	°C/W	6

¹ Junction temperature is a function of die size, on-chip power dissipation, package thermal resistance, mounting site (board) temperature, ambient temperature, air flow, power dissipation of other components on the board, and board thermal resistance.

² Per JEDEC JESD51-2 with natural convection for horizontally oriented board. Board meets JESD51-9 specification for 1s or 2s2p board, respectively.

³ Per JEDEC JESD51-6 with forced convection for horizontally oriented board. Board meets JESD51-9 specification for 1s or 2s2p board, respectively.

⁴ Thermal resistance between the die and the printed circuit board per JEDEC JESD51-8. Board temperature is measured on the top surface of the board near the package.

⁵ Thermal resistance between the die and the case top surface as measured by the cold plate method (MIL SPEC-883 Method 1012.1).

⁶ Thermal characterization parameter indicating the temperature difference between package top and the junction temperature per JEDEC JESD51-2. When Greek letters are not available, the thermal characterization parameter is written as Psi-JT.

4.1.3 Operating ranges

Table 11 provides the operating ranges of the i.MX RT1020 processors. For details on the chip's power structure, see the “Power Management Unit (PMU)” chapter of the *i.MX RT1020 Reference Manual (IMXRT1020RM)*.

Table 11. Operating ranges

Parameter Description	Symbol	Operating Conditions	Min	Typ	Max ¹	Unit	Comment
-----------------------	--------	----------------------	-----	-----	------------------	------	---------

Table 11. Operating ranges (continued)

Run Mode	VDD_SOC_IN	M7 core at 396 MHz	1.15	—	1.26	V	—
	VDD_SOC_IN	M7 core at 132 MHz	1.15	—	1.26		—
		M7 core at 24 MHz	0.925	—	1.26		—
IDLE Mode	VDD_SOC_IN	M7 core operation at 396 MHz or below	1.15	—	1.26	V	—
SUSPEND (DSM) Mode	VDD_SOC_IN	—	0.925	—	1.26	V	Refer to Table 14 Low power mode current and power consumption
SNVS Mode	VDD_SOC_IN	—	0	—	1.26	V	—
Power for DCDC	DCDC_IN	—	3.0	3.3	3.6		—
VDD_HIGH internal regulator	VDD_HIGH_IN ²	—	3.0	—	3.6	V	Must match the range of voltages that the rechargeable backup battery supports.
Backup battery supply range	VDD_SNVS_IN ³	—	2.40	—	3.6	V	Can be combined with VDDHIGH_IN, if the system does not require keeping real time and other data on OFF state.
USB supply voltages	USB_OTG1_VBUS	—	4.40	—	5.5	V	—
GPIO supplies	NVCC_GPIO	—	3.0	3.3	3.6	V	All digital I/O supplies (NVCC_xxxx) must be powered (unless otherwise specified in this data sheet) under normal conditions whether the associated I/O pins are in use or not.
	NVCC_SD0	—	1.65	1.8, 3.3	3.6	V	
A/D converter	VDDA_ADC_3P3	—	3.0	3.3	3.6	V	VDDA_ADC_3P3 must be powered even if the ADC is not used. VDDA_ADC_3P3 cannot be powered when the other SoC supplies (except VDD_SNVS_IN) are off.
Temperature Operating Ranges							
Junction temperature	T _j	Standard Commercial	-40	—	105	°C	See the application note, i.MX RT1020 Product Lifetime Usage Estimates for information on product lifetime (power-on years) for this processor.

¹ Applying the maximum voltage results in maximum power consumption and heat generation. NXP recommends a voltage set point = (V_{min} + the supply tolerance). This result in an optimized power/speed ratio.

² Applying the maximum voltage results in shorten lifetime. 3.6 V usage limited to < 1% of the use profile. Reset of profile limited to below 3.49 V.

³ In setting VDD_SNVS_IN voltage with regards to Charging Currents and RTC, refer to the *i.MX RT1020 Hardware Development Guide* (IMXRT1020HDG).

4.1.4 External clock sources

Each i.MX RT1020 processor has two external input system clocks: a low frequency (RTC_XTALI) and a high frequency (XTALI).

The RTC_XTALI is used for low-frequency functions. It supplies the clock for wake-up circuit, power-down real time clock operation, and slow system and watch-dog counters. The clock input can be connected to either external oscillator or a crystal using internal oscillator amplifier. Additionally, there is an internal ring oscillator, which can be used instead of the RTC_XTALI if accuracy is not important.

The system clock input XTALI is used to generate the main system clock. It supplies the PLLs and other peripherals. The system clock input can be connected to either external oscillator or a crystal using internal oscillator amplifier.

Table 12 shows the interface frequency requirements.

Table 12. External input clock frequency

Parameter Description	Symbol	Min	Typ	Max	Unit
RTC_XTALI Oscillator ^{1,2}	f_{ckil}	—	32.768 ³ /32.0	—	kHz
XTALI Oscillator ^{2,4}	f_{xtal}	—	24	—	MHz

¹ External oscillator or a crystal with internal oscillator amplifier.

² The required frequency stability of this clock source is application dependent. For recommendations, see the *Hardware Development Guide for i.MX RT1020 Crossover Processors* (IMXRT1020HDG).

³ Recommended nominal frequency 32.768 kHz.

⁴ External oscillator or a fundamental frequency crystal with internal oscillator amplifier.

The typical values shown in Table 12 are required for use with NXP SDK to ensure precise time keeping and USB operation. For RTC_XTALI operation, two clock sources are available.

- On-chip 40 kHz ring oscillator—this clock source has the following characteristics:
 - Approximately 25 μ A more I_{dd} than crystal oscillator
 - Approximately \pm 50% tolerance
 - No external component required
 - Starts up quicker than 32 kHz crystal oscillator
- External crystal oscillator with on-chip support circuit:
 - At power up, ring oscillator is utilized. After crystal oscillator is stable, the clock circuit switches over to the crystal oscillator automatically.
 - Higher accuracy than ring oscillator
 - If no external crystal is present, then the ring oscillator is utilized

The decision of choosing a clock source should be taken based on real-time clock use and precision time-out.

4.1.5 Maximum supply currents

The data shown in [Table 13](#) represent a use case designed specifically to show the maximum current consumption possible. All cores are running at the defined maximum frequency and are limited to L1 cache accesses only to ensure no pipeline stalls. Although a valid condition, it would have a very limited practical use case, if at all, and be limited to an extremely low duty cycle unless the intention was to specifically show the worst case power consumption.

See the *i.MX RT1020 Power Consumption Measurement Application Note* for more details on typical power consumption under various use case definitions.

Table 13. Maximum supply currents

Power Rail	Conditions	Max Current	Unit
DCDC_IN	Max power for FF chip at 125 °C	80	mA
VDD_HIGH_IN	Include internal loading in analog	50	mA
VDD_SNVS_IN	—	250	μA
USB_OTG1_VBUS	25 mA for each active USB interface	25	mA
VDDA_ADC_3P3	3.3 V power supply for 12-bit ADC, 600 μA typical, 750 μA max, for each ADC. 100 Ohm max loading for touch panel, cause 33 mA current.	40	mA
NVCC_GPIO NVCC_SD0	$I_{max} = N \times C \times V \times (0.5 \times F)$ Where: N—Number of IO pins supplied by the power line C—Equivalent external capacitive load V—IO voltage (0.5 x F)—Data change rate. Up to 0.5 of the clock rate (F) In this equation, I _{max} is in Amps, C in Farads, V in Volts, and F in Hertz.		

4.1.6 Low power mode supply currents

Table 14 shows the current core consumption (not including I/O) of i.MX RT1020 processors in selected low power modes.

Table 14. Low power mode current and power consumption

Mode	Test Conditions	Supply	Typical ¹	Units
SYSTEM IDLE	<ul style="list-style-type: none"> LDO_ARM and LDO_SOC set to the Bypass mode LDO_2P5 set to 2.5 V, LDO_1P1 set to 1.1 V CPU in WFI, CPU clock gated 24 MHz XTAL is ON System PLL is active, other PLLs are power down Peripheral clock gated, but remain powered 	DCDC_IN (3.3 V)	4	mA
		VDD_HIGH_IN (3.3 V)	5.2	
		VDD_SNVS_IN (3.3 V)	0.036	
		Total	30.479	mW
LOW POWER IDLE	<ul style="list-style-type: none"> LDO_SOC is in the Bypass mode, LDO_ARM is in the PG mode LDO_2P5 and LDO_1P1 are set to Weak mode CPU in Power Gate mode All PLLs are power down 24 MHz XTAL is off, 24 MHz RCOSC used as clock source Peripheral are powered off 	DCDC_IN (3.3 V)	2	mA
		VDD_HIGH_IN (3.3 V)	0.4	
		VDD_SNVS_IN (3.3 V)	0.05	
		Total	8.085	mW
SUSPEND (DSM)	<ul style="list-style-type: none"> LDO_SOC is in the Bypass mode, LDO_ARM is in the PG mode LDO_2P5 and LDO_1P1 are shut off CPU in Power Gate mode All PLLs are power down 24 MHz XTAL is off, 24 MHz RCOSC is off All clocks are shut off, except 32 kHz RTC Peripheral are powered off 	DCDC_IN (3.3 V)	0.3	mA
		VDD_HIGH_IN (3.3 V)	0.09	
		VDD_SNVS_IN (3.3 V)	0.03	
		Total	1.386	mW
SNVS (RTC)	<ul style="list-style-type: none"> All SOC digital logic, analog module are shut off 32 kHz RTC is alive 	DCDC_IN (0 V)	0	mA
		VDD_HIGH_IN (0 V)	0	
		VDD_SNVS_IN (3.3 V)	0.020	
		Total	0.066	mW

¹ The typical values shown here are for information only and are not guaranteed. These values are average values measured on a typical process wafer at 25°C.

4.1.7 USB PHY current consumption

4.1.7.1 Power down mode

In power down mode, everything is powered down, including the USB VBUS valid detectors in typical condition. Table 15 shows the USB interface current consumption in power down mode.

Table 15. USB PHY current consumption in power down mode

	VDD_USB_CAP (3.0 V)	VDD_HIGH_CAP (2.5 V)	NVCC_PLL (1.1 V)
Current	5.1 μ A	1.7 μ A	< 0.5 μ A

NOTE

The currents on the VDD_HIGH_CAP and VDD_USB_CAP were identified to be the voltage divider circuits in the USB-specific level shifters.

4.2 System power and clocks

This section provide the information about the system power and clocks.

4.2.1 Power supplies requirements and restrictions

The system design must comply with power-up sequence, power-down sequence, and steady state guidelines as described in this section to guarantee the reliable operation of the device. Any deviation from these sequences may result in the following situations:

- Excessive current during power-up phase
- Prevention of the device from booting
- Irreversible damage to the processor (worst-case scenario)

4.2.1.1 Power-up sequence

The below restrictions must be followed:

- VDD_SNVS_IN supply must be turned on before any other power supply or be connected (shorted) with VDD_HIGH_IN supply.
- If a coin cell is used to power VDD_SNVS_IN, then ensure that it is connected before any other supply is switched on.
- When internal DCDC is enabled, external delay circuit is required to delay the “DCDC_PSWITCH” signal 1 ms after DCDC_IN is stable.
- POR_B should be held low during the entire power up sequence.

NOTE

The POR_B input (if used) must be immediately asserted at power-up and remain asserted until after the last power rail reaches its working voltage. In the absence of an external reset feeding the POR_B input, the internal POR module takes control. See the *i.MX RT1020 Reference Manual (IMXRT1020RM)* for further details and to ensure that all necessary requirements are being met.

NOTE

Need to ensure that there is no back voltage (leakage) from any supply on the board towards the 3.3 V supply (for example, from the external components that use both the 1.8 V and 3.3 V supplies).

NOTE

USB_OTG1_VBUS and VDDA_ADC_3P3 are not part of the power supply sequence and may be powered at any time.

4.2.1.2 Power-down sequence

The following restrictions must be followed:

- VDD_SNVS_IN supply must be turned off after any other power supply or be connected (shorted) with VDD_HIGH_IN supply.
- If a coin cell is used to power VDD_SNVS_IN, then ensure that it is removed after any other supply is switched off.

4.2.1.3 Power supplies usage

All I/O pins should not be externally driven while the I/O power supply for the pin (NVCC_XXX) is OFF. This can cause internal latch-up and malfunctions due to reverse current flows. For information about I/O power supply of each pin, see “Power Rail” columns in pin list tables of [Section 6, Package information and contact assignments](#).

4.2.2 Integrated LDO voltage regulator parameters

Various internal supplies can be powered ON from internal LDO voltage regulators. All the supply pins named *_CAP must be connected to external capacitors. The on-board LDOs are intended for internal use only and should not be used to power any external circuitry. See the *i.MX RT1020 Reference Manual (IMXRT1020RM)* for details on the power tree scheme.

NOTE

The *_CAP signals should not be powered externally. These signals are intended for internal LDO operation only.

4.2.2.1 Digital regulators (LDO_SNVS)

There are one digital LDO regulator (“Digital”, because of the logic loads that they drive, not because of their construction). The advantages of the regulator is to reduce the input supply variation because of its input supply ripple rejection and its on-die trimming. This translates into more stable voltage for the on-chip logics.

The regulator has two basic modes:

- Power Gate. The regulation FET is switched fully off limiting the current draw from the supply. The analog part of the regulator is powered down here limiting the power consumption.
- Analog regulation mode. The regulation FET is controlled such that the output voltage of the regulator equals the programmed target voltage. The target voltage is fully programmable in 25 mV steps.

For additional information, see the *i.MX RT1020 Reference Manual (IMXRT1020RM)*.

4.2.2.2 Regulators for analog modules

4.2.2.2.1 LDO_1P1

The LDO_1P1 regulator implements a programmable linear-regulator function from VDD_HIGH_IN (see [Table 11](#) for minimum and maximum input requirements). Typical Programming Operating Range is 1.0 V to 1.2 V with the nominal default setting as 1.1 V. The LDO_1P1 supplies the USB Phy, and PLLs. A programmable brown-out detector is included in the regulator that can be used by the system to determine when the load capability of the regulator is being exceeded to take the necessary steps. Current-limiting can be enabled to allow for in-rush current requirements during start-up, if needed. Active-pull-down can also be enabled for systems requiring this feature.

For information on external capacitor requirements for this regulator, see the *Hardware Development Guide for i.MX RT1020 Crossover Processors* (IMXRT1020HDG).

For additional information, see the *i.MX RT1020 Reference Manual* ([IMXRT1020RM](#)).

4.2.2.2.2 LDO_2P5

The LDO_2P5 module implements a programmable linear-regulator function from VDD_HIGH_IN (see [Table 11](#) for minimum and maximum input requirements). Typical Programming Operating Range is 2.25 V to 2.75 V with the nominal default setting as 2.5 V. LDO_2P5 supplies the USB PHY, E-fuse module, and PLLs. A programmable brown-out detector is included in the regulator that can be used by the system to determine when the load capability of the regulator is being exceeded, to take the necessary steps. Current-limiting can be enabled to allow for in-rush current requirements during start-up, if needed. Active-pull-down can also be enabled for systems requiring this feature. An alternate self-biased low-precision weak-regulator is included that can be enabled for applications needing to keep the output voltage alive during low-power modes where the main regulator driver and its associated global bandgap reference module are disabled. The output of the weak-regulator is not programmable and is a function of the input supply as well as the load current. Typically, with a 3 V input supply the weak-regulator output is 2.525 V and its output impedance is approximately 40 Ω .

For information on external capacitor requirements for this regulator, see the *Hardware Development Guide for i.MX RT1020 Crossover Processors* (IMXRT1020HDG).

For additional information, see the *i.MX RT1020 Reference Manual* ([IMXRT1020RM](#)).

4.2.2.2.3 LDO_USB

The LDO_USB module implements a programmable linear-regulator function from the USB VUSB voltages (4.4 V–5.5 V) to produce a nominal 3.0 V output voltage. A programmable brown-out detector is included in the regulator that can be used by the system to determine when the load capability of the regulator is being exceeded, to take the necessary steps. This regulator has a built in power-mux that allows the user to select to run the regulator from either USB VBUS supply, when both are present. If only one of the USB VBUS voltages is present, then, the regulator automatically selects this supply. Current limit is also included to help the system meet in-rush current targets.

For information on external capacitor requirements for this regulator, see the *Hardware Development Guide for i.MX RT1020 Crossover Processors* (IMXRT1020HDG).

For additional information, see the *i.MX RT1020 Reference Manual* ([IMXRT1020RM](#)).

4.2.2.2.4 DCDC

DCDC can be configured to operate on power-save mode when the load current is less than 50 mA. During the power-save mode, the converter operates with reduced switching frequency in PFM mode and with a minimum quiescent current to maintain high efficiency.

DCDC can detect the peak current in the P-channel switch. When the peak current exceeds the threshold, DCDC will give an alert signal, and the threshold can be configured. By this way, DCDC can roughly detect the current loading.

DCDC also includes the following protection functions:

- Over current protection. In run mode, DCDC shuts down when detecting abnormal large current in the P-type power switch. In power save mode, DCDC stop charging inductor when detecting large current in the P-type power switch. The threshold is also different in run mode and in power save mode: the former is 1 A–2A, and the latter is 200 mA–250 mA.
- Over voltage protection. DCDC shuts down when detecting the output voltage is too high.
- Low voltage detection. DCDC shuts down when detecting the input voltage is too low.

For additional information, see the *i.MX RT1020 Reference Manual* ([IMXRT1020RM](#)).

4.2.3 PLL's electrical characteristics

This section provides PLL electrical characteristics.

4.2.3.1 Audio/Video PLL's electrical parameters

Table 16. Audio/video PLL's electrical parameters

Parameter	Value
Clock output range	650 MHz ~1.3 GHz
Reference clock	24 MHz
Lock time	< 11250 reference cycles

4.2.3.2 System PLL

Table 17. System PLL's electrical parameters

Parameter	Value
Clock output range	528 MHz PLL output
Reference clock	24 MHz
Lock time	< 11250 reference cycles

4.2.3.3 Ethernet PLL

Table 18. Ethernet PLL's electrical parameters

Parameter	Value
Clock output range	1 GHz
Reference clock	25 MHz
Lock time	< 11250 reference cycles

4.2.3.4 USB PLL

Table 19. USB PLL's electrical parameters

Parameter	Value
Clock output range	480 MHz PLL output
Reference clock	24 MHz
Lock time	< 383 reference cycles

4.2.4 On-chip oscillators

4.2.4.1 OSC24M

This block implements an amplifier that when combined with a suitable quartz crystal and external load capacitors implement an oscillator. The oscillator is powered from NVCC_PLL.

The system crystal oscillator consists of a Pierce-type structure running off the digital supply. A straight forward biased-inverter implementation is used.

4.2.4.2 OSC32K

This block implements an amplifier that when combined with a suitable quartz crystal and external load capacitors implement a low power oscillator. It also implements a power mux such that it can be powered from either a ~3 V backup battery (VDD_SNVS_IN) or VDD_HIGH_IN such as the oscillator consumes power from VDD_HIGH_IN when that supply is available and transitions to the backup battery when VDD_HIGH_IN is lost.

In addition, if the clock monitor determines that the OSC32K is not present, then the source of the 32 K will automatically switch to a crude internal ring oscillator. The frequency range of this block is approximately 10–45 kHz. It highly depends on the process, voltage, and temperature.

The OSC32k runs from VDD_SNVS_CAP supply, which comes from the VDD_HIGH_IN/VDD_SNVS_IN. The target battery is a ~3 V coin cell. Proper choice of coin cell type is necessary for chosen VDD_HIGH_IN range. Appropriate series resistor (Rs) must be used when connecting the coin cell. Rs depends on the charge current limit that depends on the chosen coin cell. For example, for Panasonic ML621:

- Average Discharge Voltage is 2.5 V
- Maximum Charge Current is 0.6 mA

For a charge voltage of 3.2 V, $R_s = (3.2-2.5)/0.6 \text{ m} = 1.17 \text{ k}$.

Table 20. OSC32K main characteristics

	Min	Typ	Max	Comments
Fosc	—	32.768 KHz	—	This frequency is nominal and determined mainly by the crystal selected. 32.0 K would work as well.
Current consumption	—	4 μA	—	The 4 μA is the consumption of the oscillator alone (OSC32k). Total supply consumption will depend on what the digital portion of the RTC consumes. The ring oscillator consumes 1 μA when ring oscillator is inactive, 20 μA when the ring oscillator is running. Another 1.5 μA is drawn from vdd_rtc in the power_detect block. So, the total current is 6.5 μA on vdd_rtc when the ring oscillator is not running.
Bias resistor	—	14 M Ω	—	This integrated bias resistor sets the amplifier into a high gain state. Any leakage through the ESD network, external board leakage, or even a scope probe that is significant relative to this value will debias the amp. The debiasing will result in low gain, and will impact the circuit's ability to start up and maintain oscillations.
Crystal Properties				
Cload	—	10 pF	—	Usually crystals can be purchased tuned for different Cloads. This Cload value is typically 1/2 of the capacitances realized on the PCB on either side of the quartz. A higher Cload will decrease oscillation margin, but increases current oscillating through the crystal.
ESR	—	50 k Ω	100 k Ω	Equivalent series resistance of the crystal. Choosing a crystal with a higher value will decrease the oscillating margin.

4.3 I/O parameters

This section provide parameters on I/O interfaces.

4.3.1 I/O DC parameters

This section includes the DC parameters of the following I/O types:

- XTALI and RTC_XTALI (Clock Inputs) DC Parameters
- General Purpose I/O (GPIO)

NOTE

The term 'NVCC_XXXX' in this section refers to the associated supply rail of an input or output.

Electrical characteristics

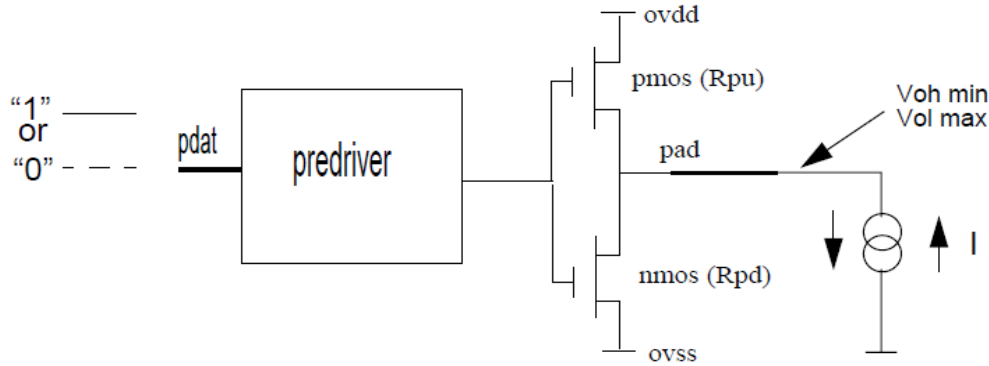

Figure 3. Circuit for parameters Voh and Vol for I/O cells

4.3.1.1 XTALI and RTC_XTALI (clock inputs) DC parameters

Table 21 shows the DC parameters for the clock inputs.

Table 21. XTALI and RTC_XTALI DC parameters¹

Parameter	Symbol	Test Conditions	Min	Max	Unit
XTALI high-level DC input voltage	Vih	—	0.8 x NVCC_PLL	NVCC_PLL	V
XTALI low-level DC input voltage	Vil	—	0	0.2	V
RTC_XTALI high-level DC input voltage	Vih	—	0.8	1.1	V
RTC_XTALI low-level DC input voltage	Vil	—	0	0.2	V

¹ The DC parameters are for external clock input only.

4.3.1.2 Single voltage general purpose I/O (GPIO) DC parameters

Table 22 shows DC parameters for GPIO pads. The parameters in Table 22 are guaranteed per the operating ranges in Table 11, unless otherwise noted.

Table 22. Single voltage GPIO DC parameters

Parameter	Symbol	Test Conditions	Min	Max	Units
High-level output voltage ¹	V _{OH}	I _{oh} = -0.1mA (ipp_dse=001,010) I _{oh} = -1mA (ipp_dse=011,100,101,110,111)	NVCC_XXXX - 0.2	—	V
Low-level output voltage ¹	V _{OL}	I _{ol} = 0.1mA (ipp_dse=001,010) I _{ol} = 1mA (ipp_dse=011,100,101,110,111)	—	0.2	V
High-Level input voltage ^{1,2}	V _{IH}	—	0.7 x NVCC_XXXX	NVCC_XXXX	V
Low-Level input voltage ^{1,2}	V _{IL}	—	0	0.3 x NVCC_XXXX	V
Input Hysteresis (NVCC_XXXX= 1.8V)	V _{HYS_LowVDD}	NVCC_XXXX=1.8V	250	—	mV

Table 22. Single voltage GPIO DC parameters (continued)

Parameter	Symbol	Test Conditions	Min	Max	Units
Input Hysteresis (NVCC_XXXX=3.3V)	VHYS_HighVDD	NVCC_XXXX=3.3V	250	—	mV
Schmitt trigger VT ^{+2,3}	VTH+	—	0.5 x NVCC_XXXX	—	mV
Schmitt trigger VT ^{-2,3}	VTH-	—	—	0.5 x NVCC_XXXX	mV
Pull-up resistor (22_kΩ PU)	RPU_22K	Vin=0V	—	212	μA
Pull-up resistor (22_kΩ PU)	RPU_22K	Vin=NVCC_XXXX	—	1	μA
Pull-up resistor (47_kΩ PU)	RPU_47K	Vin=0V	—	100	μA
Pull-up resistor (47_kΩ PU)	RPU_47K	Vin=NVCC_XXXX	—	1	μA
Pull-up resistor (100_kΩ PU)	RPU_100K	Vin=0V	—	48	μA
Pull-up resistor (100_kΩ PU)	RPU_100K	Vin=NVCC_XXXX	—	1	μA
Pull-down resistor (100_kΩ PD)	RPD_100K	Vin=NVCC_XXXX	—	48	μA
Pull-down resistor (100_kΩ PD)	RPD_100K	Vin=0V	—	1	μA
Input current (no PU/PD)	IIN	VI = 0, VI = NVCC_XXXX	-1	1	μA
Keeper Circuit Resistance	R_Keeper	VI = 0.3 x NVCC_XXXX, VI = 0.7 x NVCC_XXXX	105	175	kΩ

¹ Overshoot and undershoot conditions (transitions above NVCC_XXXX and below GND) on switching pads must be held below 0.6 V, and the duration of the overshoot/undershoot must not exceed 10% of the system clock cycle. Overshoot/undershoot must be controlled through printed circuit board layout, transmission line impedance matching, signal line termination, or other methods. Non-compliance to this specification may affect device reliability or cause permanent damage to the device.

² To maintain a valid level, the transition edge of the input must sustain a constant slew rate (monotonic) from the current DC level through to the target DC level, Vil or Vih. Monotonic input transition time is from 0.1 ns to 1 s.

³ Hysteresis of 250 mV is guaranteed over all operating conditions when hysteresis is enabled.

4.3.2 I/O AC parameters

This section includes the AC parameters of the following I/O types:

- General Purpose I/O (GPIO)

Figure 4 shows load circuit for output, and Figure 5 show the output transition time waveform.

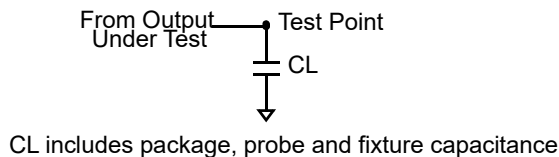

Figure 4. Load circuit for output

Electrical characteristics

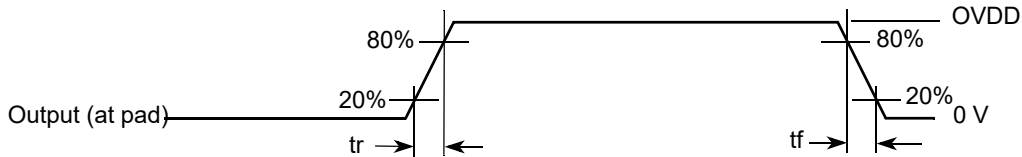

Figure 5. Output transition time waveform

4.3.2.1 General purpose I/O AC parameters

The I/O AC parameters for GPIO in slow and fast modes are presented in the [Table 23](#) and [Table 24](#), respectively. Note that the fast or slow I/O behavior is determined by the appropriate control bits in the IOMUXC control registers.

Table 23. General purpose I/O AC parameters 1.8 V mode

Parameter	Symbol	Test Condition	Min	Typ	Max	Unit
Output Pad Transition Times, rise/fall (Max Drive, ipp_dse=111)	tr, tf	15 pF Cload, slow slew rate 15 pF Cload, fast slew rate	—	—	2.72/2.79 1.51/1.54	ns
Output Pad Transition Times, rise/fall (High Drive, ipp_dse=101)	tr, tf	15 pF Cload, slow slew rate 15 pF Cload, fast slew rate	—	—	3.20/3.36 1.96/2.07	
Output Pad Transition Times, rise/fall (Medium Drive, ipp_dse=100)	tr, tf	15 pF Cload, slow slew rate 15 pF Cload, fast slew rate	—	—	3.64/3.88 2.27/2.53	
Output Pad Transition Times, rise/fall (Low Drive, ipp_dse=011)	tr, tf	15 pF Cload, slow slew rate 15 pF Cload, fast slew rate	—	—	4.32/4.50 3.16/3.17	
Input Transition Times ¹	trm	—	—	—	25	ns

¹ Hysteresis mode is recommended for inputs with transition times greater than 25 ns.

Table 24. General purpose I/O AC parameters 3.3 V mode

Parameter	Symbol	Test condition	Min	Typ	Max	Unit
Output Pad Transition Times, rise/fall (Max Drive, ipp_dse=101)	tr, tf	15 pF Cload, slow slew rate 15 pF Cload, fast slew rate	—	—	1.70/1.79 1.06/1.15	ns
Output Pad Transition Times, rise/fall (High Drive, ipp_dse=011)	tr, tf	15 pF Cload, slow slew rate 15 pF Cload, fast slew rate	—	—	2.35/2.43 1.74/1.77	
Output Pad Transition Times, rise/fall (Medium Drive, ipp_dse=010)	tr, tf	15 pF Cload, slow slew rate 15 pF Cload, fast slew rate	—	—	3.13/3.29 2.46/2.60	
Output Pad Transition Times, rise/fall (Low Drive, ipp_dse=001)	tr, tf	15 pF Cload, slow slew rate 15 pF Cload, fast slew rate	—	—	5.14/5.57 4.77/5.15	ns
Input Transition Times ¹	trm	—	—	—	25	ns

¹ Hysteresis mode is recommended for inputs with transition times greater than 25 ns.

4.3.3 Output buffer impedance parameters

This section defines the I/O impedance parameters of the i.MX RT1020 processors for the following I/O types:

- Single Voltage General Purpose I/O (GPIO)

NOTE

GPIO I/O output driver impedance is measured with “long” transmission line of impedance Z_{tl} attached to I/O pad and incident wave launched into transmission line. R_{pu}/R_{pd} and Z_{tl} form a voltage divider that defines specific voltage of incident wave relative to $NVCC_XXXX$. Output driver impedance is calculated from this voltage divider (see [Figure 6](#)).

Electrical characteristics

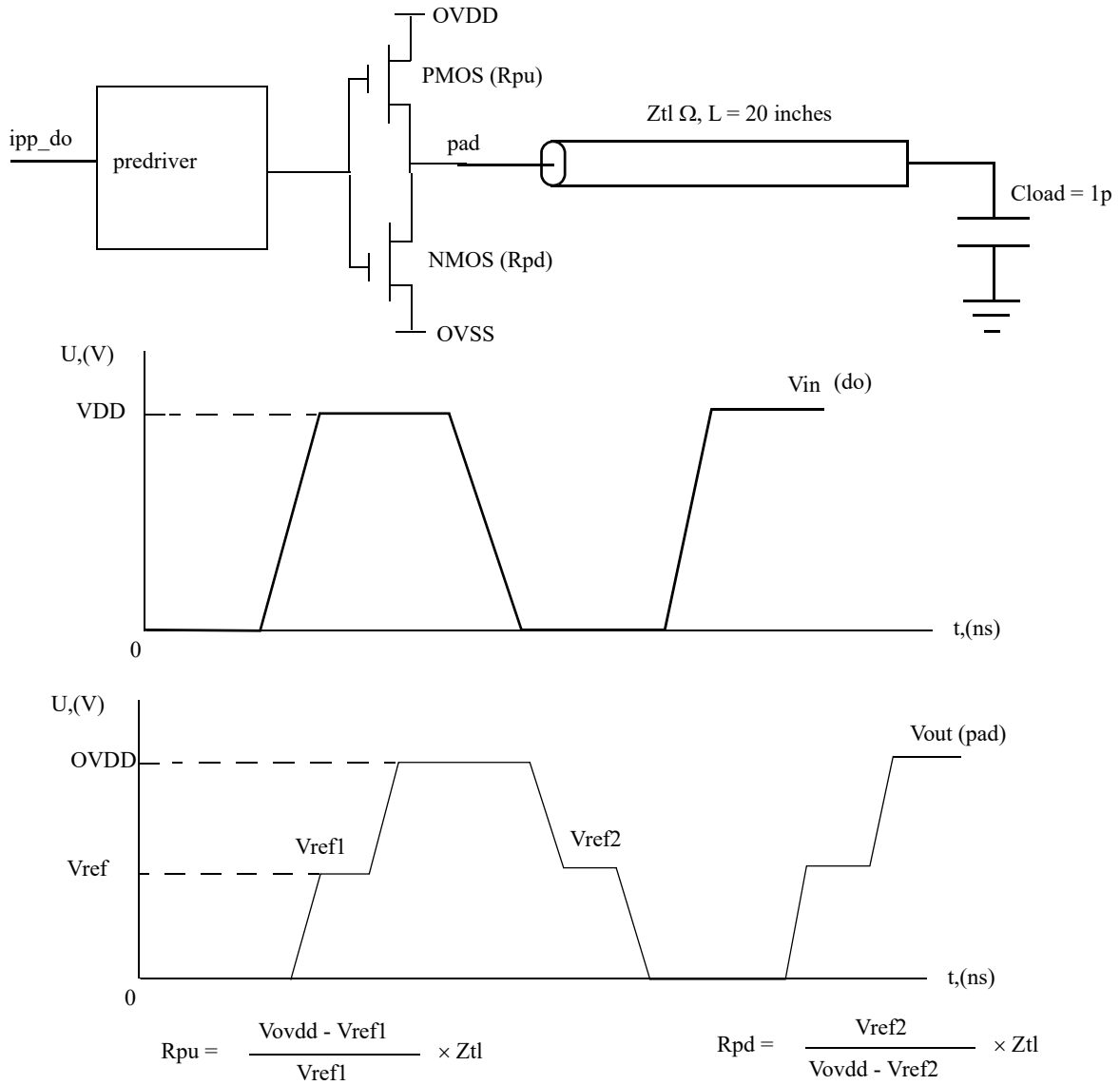

Figure 6. Impedance matching load for measurement

4.3.3.1 Single voltage GPIO output buffer impedance

Table 25 shows the GPIO output buffer impedance (NVCC_XXXX 1.8 V).

Table 25. GPIO output buffer average impedance (NVCC_XXXX 1.8 V)

Parameter	Symbol	Drive strength (DSE)	Typ value	Unit
Output Driver Impedance	Rdrv	001	260	Ω
		010	130	
		011	88	
		100	65	
		101	52	
		110	43	
		111	37	

Table 26 shows the GPIO output buffer impedance (NVCC_XXXX 3.3 V).

Table 26. GPIO Output buffer average impedance (NVCC_XXXX 3.3 V)

Parameter	Symbol	Drive strength (DSE)	Typ value	Unit
Output Driver Impedance	Rdrv	001	157	Ω
		010	78	
		011	53	
		100	39	
		101	32	
		110	26	
		111	23	

4.4 System modules

This section contains the timing and electrical parameters for the modules in the i.MX RT1020 processor.

4.4.1 Reset timings parameters

Figure 7 shows the reset timing and Table 27 lists the timing parameters.

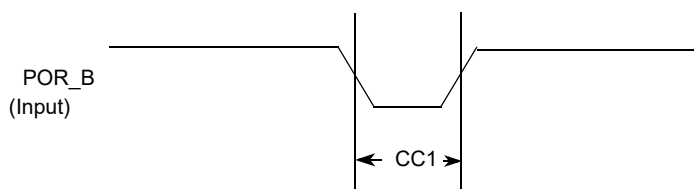

Figure 7. Reset timing diagram

Table 27. Reset timing parameters

ID	Parameter	Min	Max	Unit
CC1	Duration of POR_B to be qualified as valid.	1	—	RTC_XTALI cycle

4.4.2 WDOG reset timing parameters

Figure 8 shows the WDOG reset timing and Table 28 lists the timing parameters.

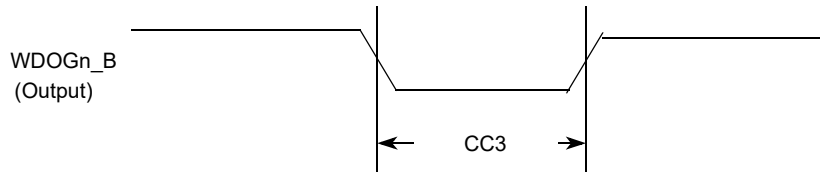

Figure 8. WDOGn_B timing diagram

Table 28. WDOGn_B timing parameters

ID	Parameter	Min	Max	Unit
CC3	Duration of WDOGn_B Assertion	1	—	RTC_XTALI cycle

NOTE

RTC_XTALI is approximately 32 kHz. RTC_XTALI cycle is one period or approximately 30 μs.

NOTE

WDOGn_B output signals (for each one of the Watchdog modules) do not have dedicated pins, but are muxed out through the IOMUX. See the IOMUX manual for detailed information.

4.4.3 SCAN JTAG Controller (SJC) timing parameters

Figure 9 depicts the SJC test clock input timing. Figure 10 depicts the SJC boundary scan timing. Figure 11 depicts the SJC test access port. Signal parameters are listed in Table 29.

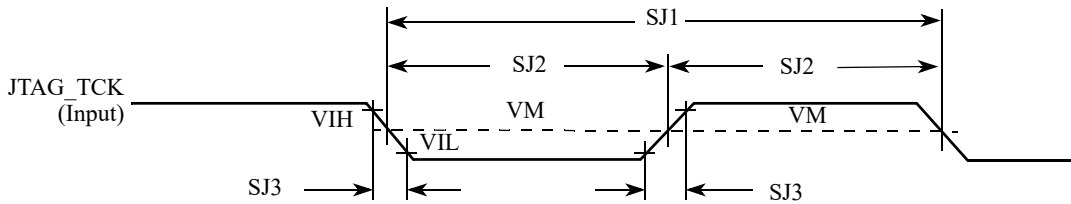

Figure 9. Test clock input timing diagram

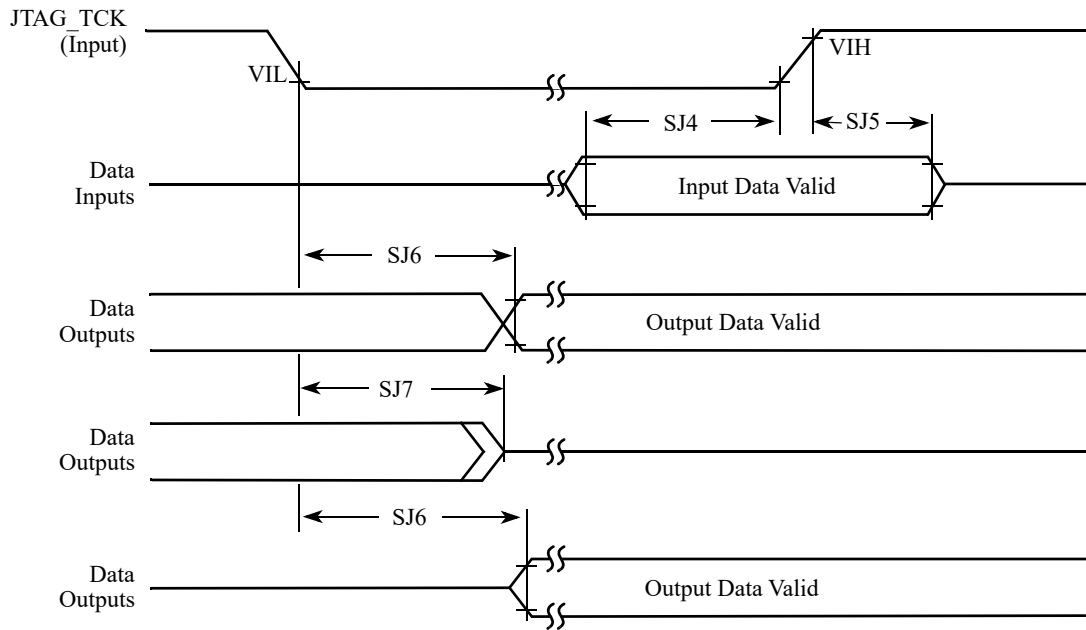

Figure 10. Boundary scan (JTAG) timing diagram

Electrical characteristics

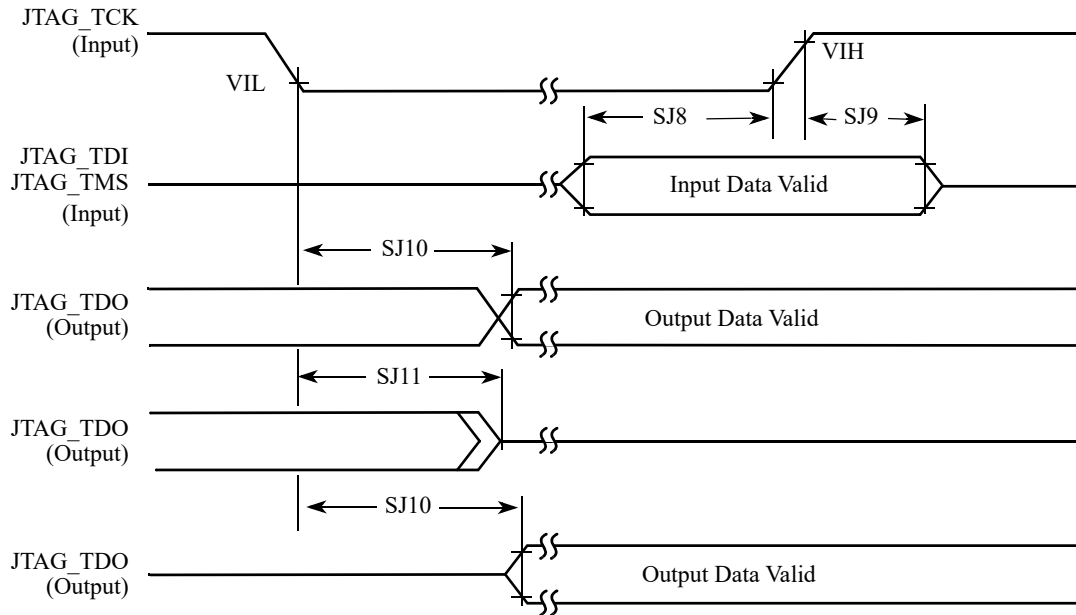

Figure 11. Test access port timing diagram

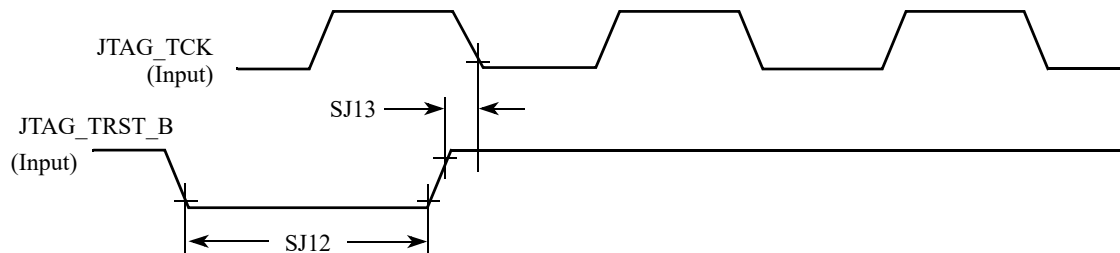

Figure 12. JTAG_TRST_B timing diagram

Table 29. JTAG timing

ID	Parameter ^{1,2}	All frequencies		Unit
		Min	Max	
SJ0	JTAG_TCK frequency of operation $1/(3 \cdot T_{DC})^1$	0.001	22	MHz
SJ1	JTAG_TCK cycle time in crystal mode	45	—	ns
SJ2	JTAG_TCK clock pulse width measured at V_M^2	22.5	—	ns
SJ3	JTAG_TCK rise and fall times	—	3	ns
SJ4	Boundary scan input data set-up time	5	—	ns
SJ5	Boundary scan input data hold time	24	—	ns
SJ6	JTAG_TCK low to output data valid	—	40	ns
SJ7	JTAG_TCK low to output high impedance	—	40	ns
SJ8	JTAG_TMS, JTAG_TDI data set-up time	5	—	ns

Table 29. JTAG timing (continued)

ID	Parameter ^{1,2}	All frequencies		Unit
		Min	Max	
SJ9	JTAG_TMS, JTAG_TDI data hold time	25	—	ns
SJ10	JTAG_TCK low to JTAG_TDO data valid	—	44	ns
SJ11	JTAG_TCK low to JTAG_TDO high impedance	—	44	ns
SJ12	JTAG_TRST_B assert time	100	—	ns
SJ13	JTAG_TRST_B set-up time to JTAG_TCK low	40	—	ns

¹ T_{DC} = target frequency of SJC

² V_M = mid-point voltage

4.4.4 Debug trace timing specifications

Table 30. Debug trace operating behaviors

Symbol	Description	Min	Max	Unit
T1	ARM_TRACE_CLK frequency of operation	—	70	MHz
T2	ARM_TRACE_CLK period	1/T1	—	MHz
T3	Low pulse width	6	—	ns
T4	High pulse width	6	—	ns
T5	Clock and data rise time	—	1	ns
T6	Clock and data fall time	—	1	ns
T7	Data setup	2	—	ns
T8	Data hold	0.7	—	ns

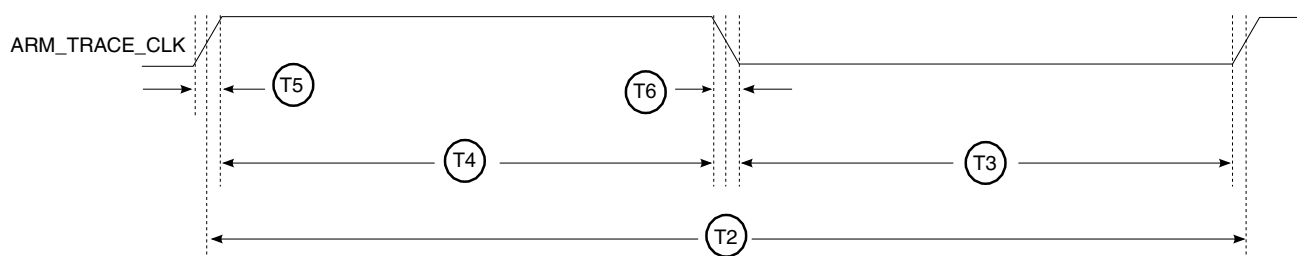

Figure 13. ARM_TRACE_CLK specifications

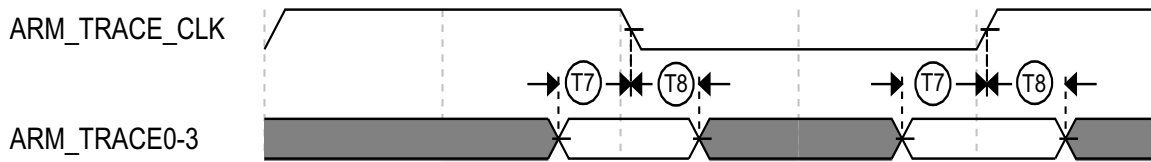

Figure 14. Trace data specifications

4.5 External memory interface

The following sections provide information about external memory interfaces.

4.5.1 SEMC specifications

The following sections provide information on SEMC interface.

Measurements are with a load of 15 pf and an input slew rate of 1 V/ns.

4.5.1.1 SEMC output timing

There are ASYNC and SYNC mode for SEMC output timing.

4.5.1.1.1 SEMC output timing in ASYNC mode

Table 31 shows SEMC output timing in ASYNC mode.

Table 31. SEMC output timing in ASYNC mode

Symbol	Parameter	Min.	Max.	Unit	Comment
	Frequency of operation	—	166	MHz	
T _{CK}	Internal clock period	6	—	ns	
T _{AVO}	Address output valid time	—	2	ns	These timing parameters apply to Address and ADV# for NOR/PSRAM in ASYNC mode.
T _{AHO}	Address output hold time	(T _{CK} - 2) ¹	—	ns	
T _{ADVL}	ADV# low time	(T _{CK} - 1) ²			
T _{DVO}	Data output valid time	—	2	ns	These timing parameters apply to Data/CLE/ALE and WE# for NAND, apply to Data/DM/CRE for NOR/PSRAM, apply to Data/DCX and WRX for DBI interface.
T _{DHO}	Data output hold time	(T _{CK} - 2) ³	—	ns	
T _{WEL}	WE# low time	(T _{CK} - 1) ⁴		ns	

¹ Address output hold time is configurable by SEMC_*CR0.AH. AH field setting value is 0x0 in above table. When AH is set with value N, T_{AHO} min time should be ((N + 1) x T_{CK}). See the *i.MX RT1020 Reference Manual (IMXRT1020RM)* for more detail about SEMC_*CR0.AH register field.

- 2 ADV# low time is configurable by SEMC_*CR0.AS. AS field setting value is 0x0 in above table. When AS is set with value N, T_{ADL} min time should be $((N + 1) \times T_{CK} - 1)$. See the *i.MX RT1020 Reference Manual (IMXRT1020RM)* for more detail about SEMC_*CR0.AS register field.
- 3 Data output hold time is configurable by SEMC_*CR0.WEH. WEH field setting value is 0x0 in above table. When WEH is set with value N, T_{DHO} min time should be $((N + 1) \times T_{CK})$. See the *i.MX RT1020 Reference Manual (IMXRT1020RM)* for more detail about SEMC_*CR0.WEH register field.
- 4 WE# low time is configurable by SEMC_*CR0.WEL. WEL field setting value is 0x0 in above table. When WEL is set with value N, T_{WEL} min time should be $((N + 1) \times T_{CK} - 1)$. See the *i.MX RT1020 Reference Manual (IMXRT1020RM)* for more detail about SEMC_*CR0.WEL register field.

Figure 15 shows the output timing in ASYNC mode.

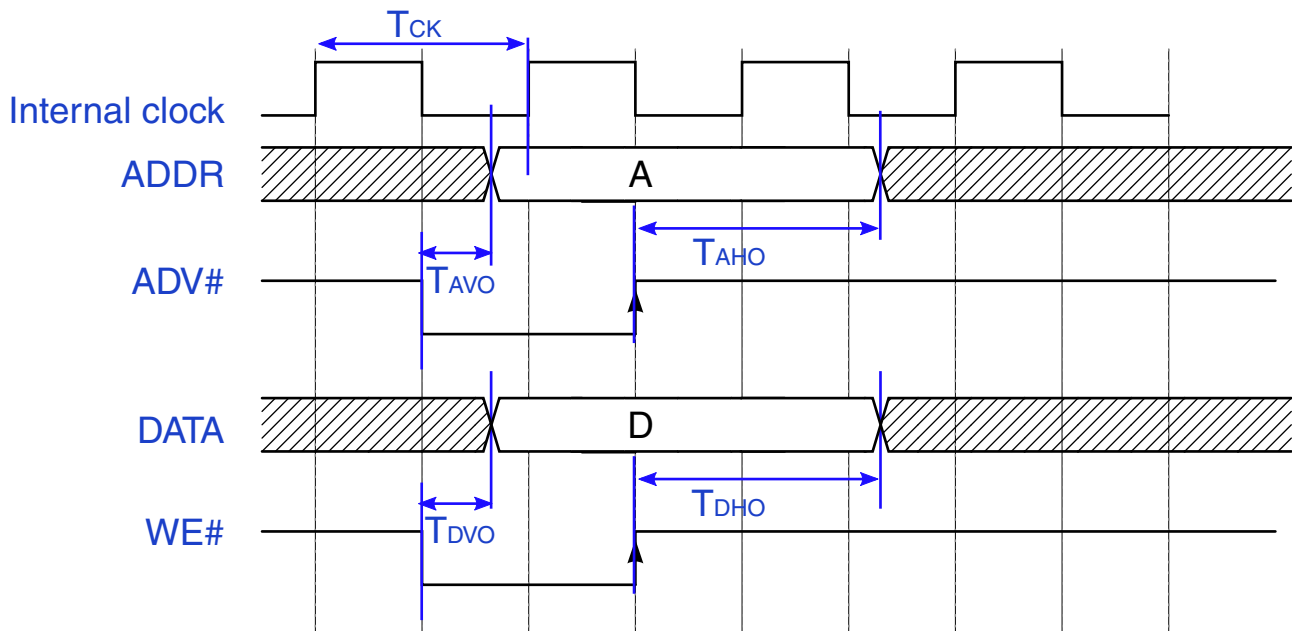

Figure 15. SEMC output timing in ASYNC mode

4.5.1.1.2 SEMC output timing in SYNC mode

Table 32 shows SEMC output timing in SYNC mode.

Table 32. SEMC output timing in SYNC mode

Symbol	Parameter	Min.	Max.	Unit	Comment
	Frequency of operation	—	166	MHz	—
T_{CK}	Internal clock period	6	—	ns	—
T_{DVO}	Data output valid time	1	—	ns	These timing parameters apply to Address/Data/DM/CKE/control signals with SEMC_CLK for SDRAM.
T_{DHO}	Data output hold time	-1	—	ns	

Figure 16 shows the output timing in SYNC mode.

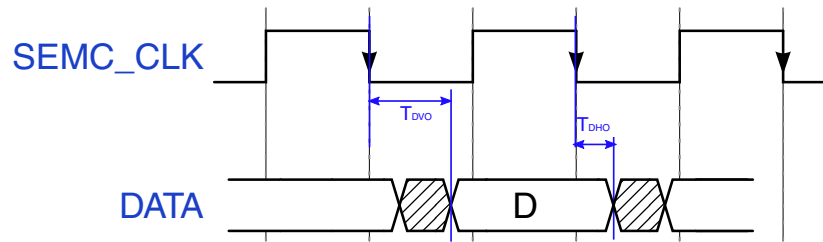

Figure 16. SEMC output timing in SYNC mode

4.5.1.2 SEMC input timing

There are ASYNC and SYNC mode for SEMC input timing.

4.5.1.2.1 SEMC input timing in ASYNC mode

Table 33 shows SEMC output timing in ASYNC mode.

Table 33. SEMC output timing in ASYNC mode

Symbol	Parameter	Min.	Max.	Unit	Comment
T_{IS}	Data input setup	8.67	—	ns	For NAND/NOR/PSRAM/DBI, these timing parameters apply to RE# and Read Data.
T_{IH}	Data input hold	0	—	ns	

Figure 17 shows the input timing in ASYNC mode.

NAND non-EDO mode and NOR/PSRAM/8080 timing

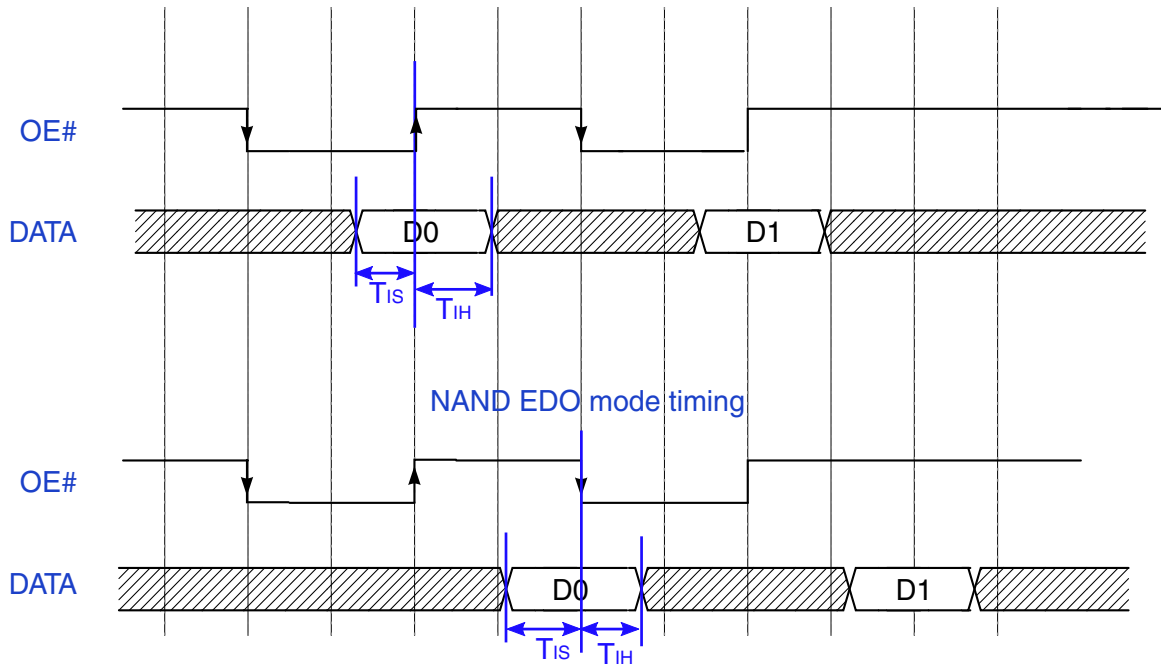

Figure 17. SEMC input timing in ASYNC mode

4.5.1.2.2 SEMC input timing in SYNC mode

Table 34 and Table 35 show SEMC input timing in SYNC mode.

Table 34. SEMC input timing in SYNC mode (SEMC_MCR.DQSMD = 0x0)

Symbol	Parameter	Min.	Max.	Unit	Comment
T_{IS}	Data input setup	8.67	—	ns	—
T_{IH}	Data input hold	0	—	ns	—

Table 35. SEMC input timing in SYNC mode (SEMC_MCR.DQSMD = 0x1)

Symbol	Parameter	Min.	Max.	Unit	Comment
T_{IS}	Data input setup	0.6	—	ns	—
T_{IH}	Data input hold	1	—	ns	—

Figure 18 shows the input timing in SYNC mode.

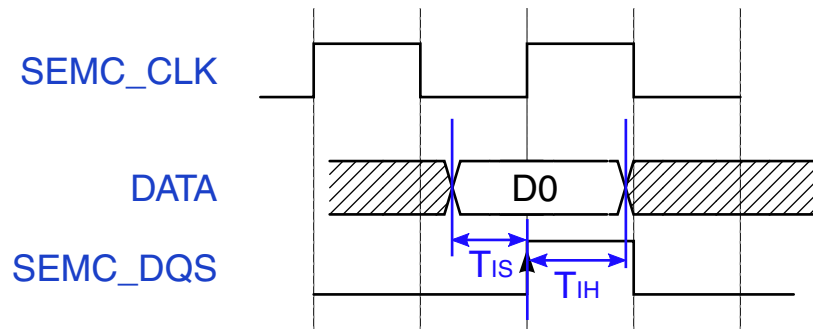

Figure 18. SEMC input timing in SYNC mode

4.5.2 FlexSPI parameters

Measurements are with a load 15 pf and input slew rate of 1 V/ns.

4.5.2.1 FlexSPI input/read timing

There are four sources for the internal sample clock for FlexSPI read data:

- Dummy read strobe generated by FlexSPI controller and looped back internally (FlexSPI_n_MCR0[RXCLKSRC] = 0x0)
- Dummy read strobe generated by FlexSPI controller and looped back through the DQS pad (FlexSPI_n_MCR0[RXCLKSRC] = 0x1)
- Read strobe provided by memory device and input from DQS pad (FlexSPI_n_MCR0[RXCLKSRC] = 0x3)

The following sections describe input signal timing for each of these four internal sample clock sources.

4.5.2.1.1 SDR mode with FlexSPI_n_MCR0[RXCLKSRC] = 0x0, 0x1

Table 36. FlexSPI input timing in SDR mode where FlexSPI_n_MCR0[RXCLKSRC] = 0X0

Symbol	Parameter	Min	Max	Unit
—	Frequency of operation	—	60	MHz
T _{IS}	Setup time for incoming data	8.67	—	ns
T _{IH}	Hold time for incoming data	0	—	ns

Table 37. FlexSPI input timing in SDR mode where FlexSPI_n_MCR0[RXCLKSRC] = 0X1

Symbol	Parameter	Min	Max	Unit
—	Frequency of operation	—	133	MHz
T _{IS}	Setup time for incoming data	2	—	ns
T _{IH}	Hold time for incoming data	1	—	ns

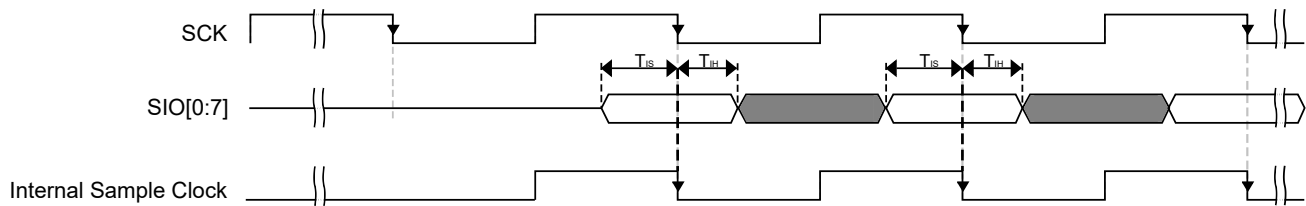

Figure 19. FlexSPI input timing in SDR mode where FlexSPIn_MCR0[RXCLKSRC] = 0X0, 0X1

NOTE

Timing shown is based on the memory generating read data on the SCK falling edge, and FlexSPI controller sampling read data on the falling edge.

4.5.2.1.2 SDR mode with FlexSPIn_MCR0[RXCLKSRC] = 0x3

There are two cases when the memory provides both read data and the read strobe in SDR mode:

- A1–Memory generates both read data and read strobe on SCK rising edge (or falling edge)
- A2–Memory generates read data on SCK falling edge and generates read strobe on SCK rising edge

Table 38. FlexSPI input timing in SDR mode where FlexSPIn_MCR0[RXCLKSRC] = 0x3 (Case A1)

Symbol	Parameter	Value		Unit
		Min	Max	
—	Frequency of operation	—	166	MHz
T_{SCKD}	Time from SCK to data valid	—	—	ns
T_{SCKDQS}	Time from SCK to DQS	—	—	ns
$T_{SCKD} - T_{SCKDQS}$	Time delta between T_{SCKD} and T_{SCKDQS}	-2	2	ns

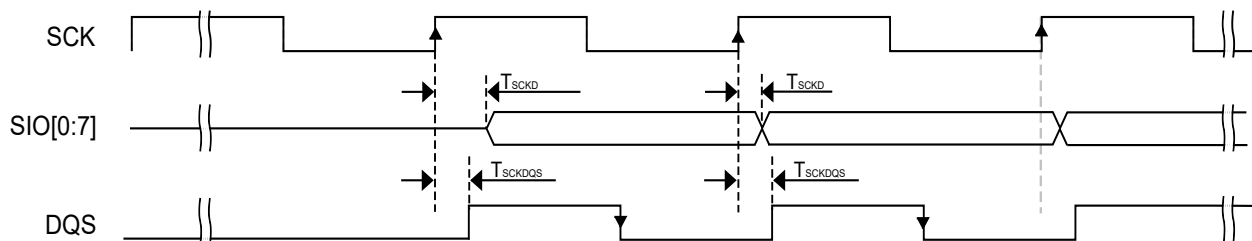

Figure 20. FlexSPI input timing in SDR mode where FlexSPIn_MCR0[RXCLKSRC] = 0X3 (Case A1)

NOTE

Timing shown is based on the memory generating read data and read strobe on the SCK rising edge. The FlexSPI controller samples read data on the DQS falling edge.

Table 39. FlexSPI input timing in SDR mode where FlexSPI_n_MCR0[RXCLKSRC] = 0x3 (Case A2)

Symbol	Parameter	Value		Unit
		Min	Max	
—	Frequency of operation	—	166	MHz
T _{SCKD}	Time from SCK to data valid	—	—	ns
T _{SCKDQS}	Time from SCK to DQS	—	—	ns
T _{SCKD} - T _{SCKDQS}	Time delta between T _{SCKD} and T _{SCKDQS}	-2	2	ns

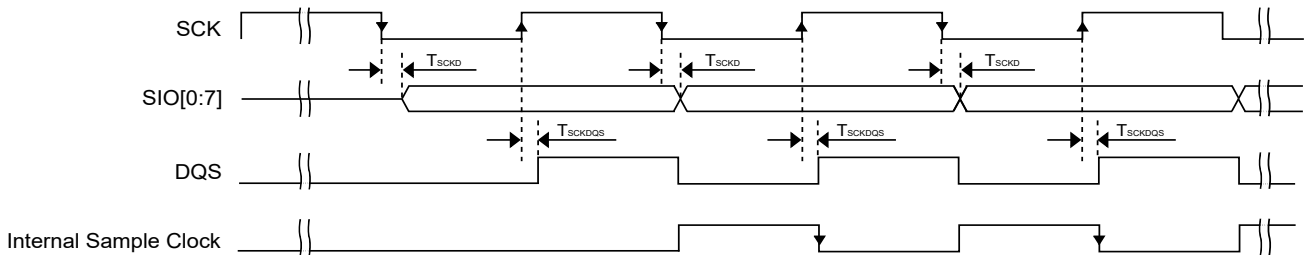

Figure 21. FlexSPI input timing in SDR mode where FlexSPI_n_MCR0[RXCLKSRC] = 0X3 (Case A2)

NOTE

Timing shown is based on the memory generating read data on the SCK falling edge and read strobe on the SCK rising edge. The FlexSPI controller samples read data on a half cycle delayed DQS falling edge.

4.5.2.1.3 DDR mode with FlexSPI_n_MCR0[RXCLKSRC] = 0x0, 0x1

Table 40. FlexSPI input timing in DDR mode where FlexSPI_n_MCR0[RXCLKSRC] = 0x0

Symbol	Parameter	Min	Max	Unit
—	Frequency of operation	—	30	MHz
T _{IS}	Setup time for incoming data	8.67	—	ns
T _{IH}	Hold time for incoming data	0	—	ns

Table 41. FlexSPI input timing in DDR mode where FlexSPI_n_MCR0[RXCLKSRC] = 0x1

Symbol	Parameter	Min	Max	Unit
—	Frequency of operation	—	66	MHz
T _{IS}	Setup time for incoming data	2	—	ns
T _{IH}	Hold time for incoming data	1	—	ns

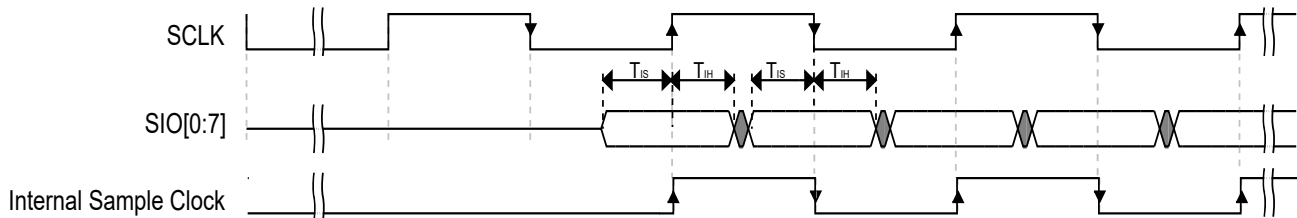
Figure 22. FlexSPI input timing in DDR mode where FlexSPI_n_MCR0[RXCLKSRC] = 0x0, 0x1

4.5.2.1.4 DDR mode with FlexSPI_n_MCR0[RXCLKSRC] = 0x3

There are two cases when the memory provides both read data and the read strobe in DDR mode:

- B1—Memory generates both read data and read strobe on SCK edge
- B2—Memory generates read data on SCK edge and generates read strobe on SCK2 edge

Table 42. FlexSPI input timing in DDR mode where FlexSPI_n_MCR0[RXCLKSRC] = 0x3 (Case B1)

Symbol	Parameter	Min	Max	Unit
—	Frequency of operation	—	166	MHz
T _{SCKD}	Time from SCK to data valid	—	—	ns
T _{SCKDQS}	Time from SCK to DQS	—	—	ns
T _{SCKD} - T _{SCKDQS}	Time delta between T _{SCKD} and T _{SCKDQS}	-1	1	ns

Electrical characteristics

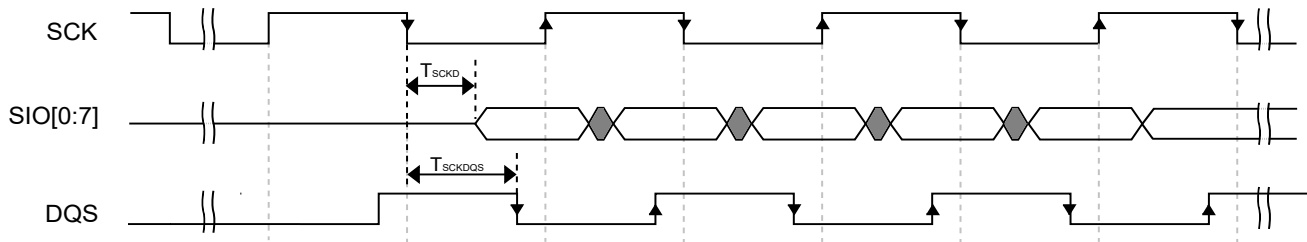

Figure 23. FlexSPI input timing in DDR mode where FlexSPI_n_MCR0[RXCLKSRC] = 0x3 (Case B1)

Table 43. FlexSPI input timing in DDR mode where FlexSPI_n_MCR0[RXCLKSRC] = 0x3 (Case B2)

Symbol	Parameter	Min	Max	Unit
—	Frequency of operation	—	166	MHz
T _{SCKD}	Time from SCK to data valid	—	—	ns
T _{SCKD} - T _{SCKDQS}	Time delta between T _{SCKD} and T _{SCKDQS}	-1	1	ns

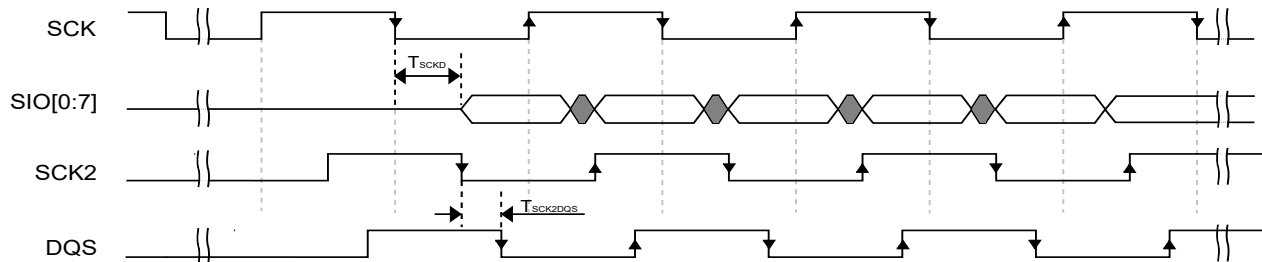

Figure 24. FlexSPI input timing in DDR mode where FlexSPI_n_MCR0[RXCLKSRC] = 0x3 (Case B2)

4.5.2.2 FlexSPI output/write timing

The following sections describe output signal timing for the FlexSPI controller including control signals and data outputs.

4.5.2.2.1 SDR mode

Table 44. FlexSPI output timing in SDR mode

Symbol	Parameter	Min	Max	Unit
—	Frequency of operation	—	166 ¹	MHz
T _{ck}	SCK clock period	6.0	—	ns
T _{DVO}	Output data valid time	—	1	ns
T _{DHO}	Output data hold time	-1	—	ns

Table 44. FlexSPI output timing in SDR mode (continued)

Symbol	Parameter	Min	Max	Unit
T_{CSS}	Chip select output setup time	$3 \times T_{CK} - 1$	—	ns
T_{CSH}	Chip select output hold time	$3 \times T_{CK} + 2$	—	ns

¹ The actual maximum frequency supported is limited by the FlexSPI_n_MCR0[RXCLKSRC] configuration used. Please refer to the FlexSPI SDR input timing specifications.

NOTE

T_{CSS} and T_{CSH} are configured by the FlexSPI_n_FLSHAxCR1 register, the default values are shown above. Please refer to the *i.MX RT1020 Reference Manual (IMXRT1020RM)* for more details.

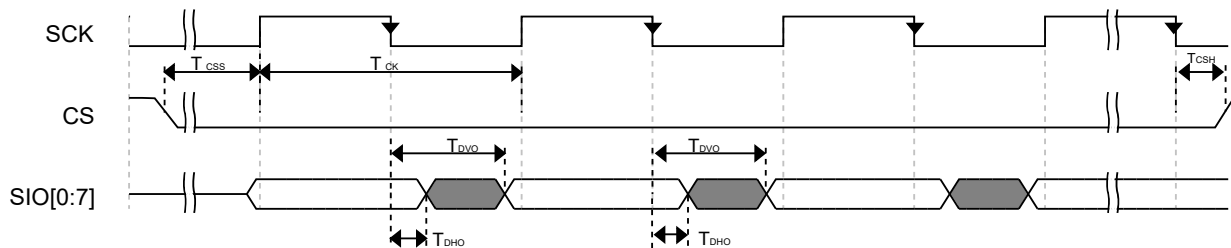

Figure 25. FlexSPI output timing in SDR mode

4.5.2.2.2 DDR mode

Table 45. FlexSPI output timing in DDR mode

Symbol	Parameter	Min	Max	Unit
—	Frequency of operation ¹	—	166	MHz
T_{ck}	SCK clock period (FlexSPI _n _MCR0[RXCLKSRC] = 0x0)	6.0	—	ns
T_{DVO}	Output data valid time	—	2.2	ns
T_{DHO}	Output data hold time	0.8	—	ns
T_{CSS}	Chip select output setup time	$3 \times T_{CK} / 2 - 0.7$	—	ns
T_{CSH}	Chip select output hold time	$3 \times T_{CK} / 2 + 0.8$	—	ns

¹ The actual maximum frequency supported is limited by the FlexSPI_n_MCR0[RXCLKSRC] configuration used. Please refer to the FlexSPI SDR input timing specifications.

NOTE

T_{CSS} and T_{CSH} are configured by the FlexSPI_n_FLSHAxCR1 register, the default values are shown above. Please refer to the *i.MX RT1020 Reference Manual (IMXRT1020RM)* for more details.

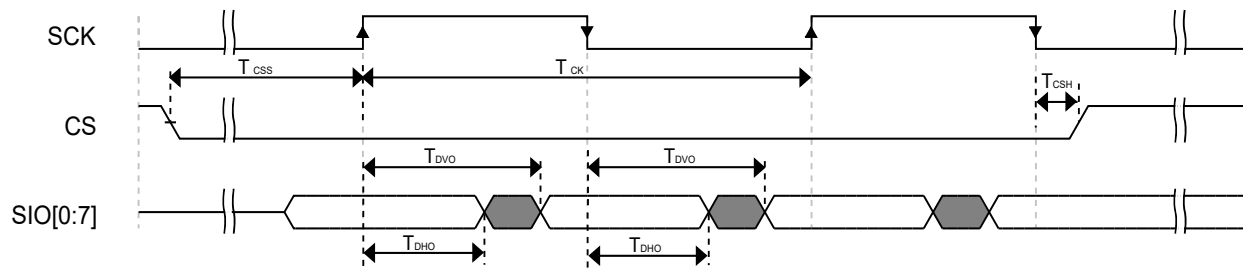

Figure 26. FlexSPI output timing in DDR mode

4.6 Audio

This section provide information about SAI/I2S and SPDIF.

4.6.1 SAI/I2S switching specifications

This section provides the AC timings for the SAI in master (clocks driven) and slave (clocks input) modes. All timings are given for non-inverted serial clock polarity (SAI_TCR[TSCKP] = 0, SAI_RCR[RSCKP] = 0) and non-inverted frame sync (SAI_TCR[TFSI] = 0, SAI_RCR[RFSI] = 0). If the polarity of the clock and/or the frame sync have been inverted, all the timings remain valid by inverting the clock signal (SAI_BCLK) and/or the frame sync (SAI_FS) shown in the figures below.

Table 46. Master mode SAI timing

Num	Characteristic	Min	Max	Unit
S1	SAI_MCLK cycle time	$2 \times t_{sys}$	—	ns
S2	SAI_MCLK pulse width high/low	40%	60%	MCLK period
S3	SAI_BCLK cycle time	$4 \times t_{sys}$	—	ns
S4	SAI_BCLK pulse width high/low	40%	60%	BCLK period
S5	SAI_BCLK to SAI_FS output valid	—	15	ns
S6	SAI_BCLK to SAI_FS output invalid	0	—	ns
S7	SAI_BCLK to SAI_TXD valid	—	15	ns
S8	SAI_BCLK to SAI_TXD invalid	0	—	ns
S9	SAI_RXD/SAI_FS input setup before SAI_BCLK	15	—	ns
S10	SAI_RXD/SAI_FS input hold after SAI_BCLK	0	—	ns

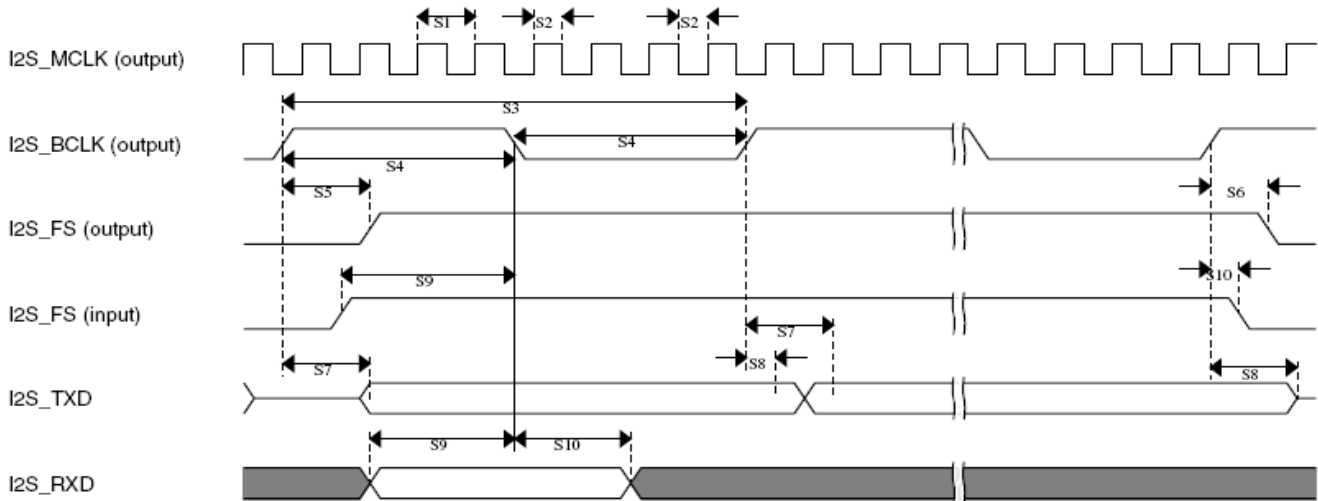

Figure 27. SAI timing—master modes

Table 47. Slave mode SAI timing

Num	Characteristic	Min	Max	Unit
S11	SAI_BCLK cycle time (input)	$4 \times t_{sys}$	—	ns
S12	SAI_BCLK pulse width high/low (input)	40%	60%	BCLK period
S13	SAI_FS input setup before SAI_BCLK	10	—	ns
S14	SAI_FA input hold after SAI_BCLK	2	—	ns
S15	SAI_BCLK to SAI_TXD/SAI_FS output valid	—	20	ns
S16	SAI_BCLK to SAI_TXD/SAI_FS output invalid	0	—	ns
S17	SAI_RXD setup before SAI_BCLK	10	—	ns
S18	SAI_RXD hold after SAI_BCLK	2	—	ns

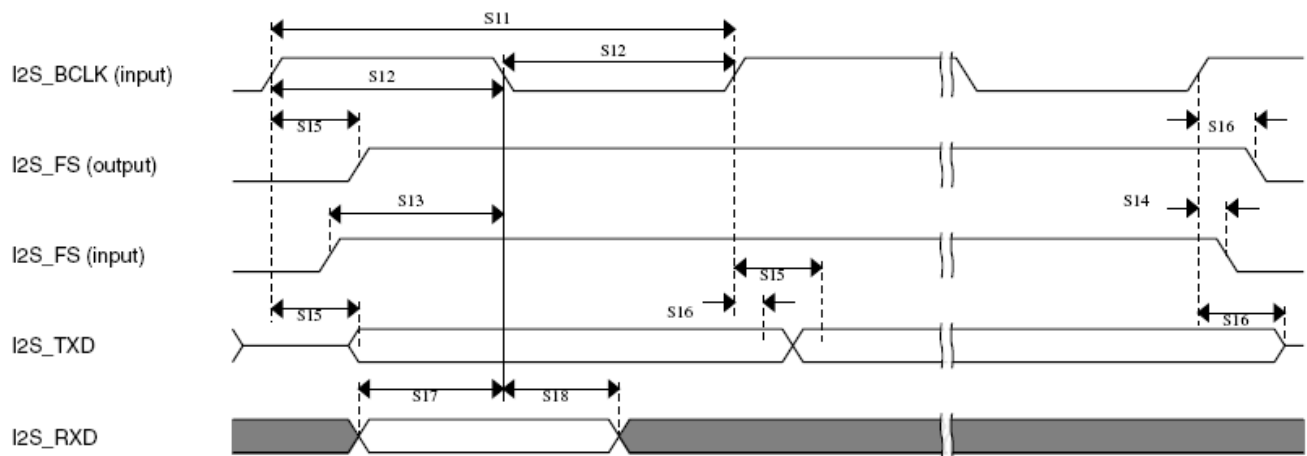

Figure 28. SAI timing—slave modes

4.6.2 SPDIF timing parameters

The Sony/Philips Digital Interconnect Format (SPDIF) data is sent using the bi-phase marking code. When encoding, the SPDIF data signal is modulated by a clock that is twice the bit rate of the data signal.

Table 48 and Figure 29 and Figure 30 show SPDIF timing parameters for the Sony/Philips Digital Interconnect Format (SPDIF), including the timing of the modulating Rx clock (SPDIF_SR_CLK) for SPDIF in Rx mode and the timing of the modulating Tx clock (SPDIF_ST_CLK) for SPDIF in Tx mode.

Table 48. SPDIF timing parameters

Characteristics	Symbol	Timing parameter range		Unit
		Min	Max	
SPDIF_IN Skew: asynchronous inputs, no specs apply	—	—	0.7	ns
SPDIF_OUT output (Load = 50pf)	—	—	1.5	ns
• Skew	—	—	24.2	
• Transition rising	—	—	31.3	
SPDIF_OUT1 output (Load = 30pf)	—	—	1.5	ns
• Skew	—	—	13.6	
• Transition rising	—	—	18.0	
Modulating Rx clock (SPDIF_SR_CLK) period	srckp	40.0	—	ns
SPDIF_SR_CLK high period	srckph	16.0	—	ns
SPDIF_SR_CLK low period	srckpl	16.0	—	ns
Modulating Tx clock (SPDIF_ST_CLK) period	stckp	40.0	—	ns
SPDIF_ST_CLK high period	stckph	16.0	—	ns
SPDIF_ST_CLK low period	stckpl	16.0	—	ns

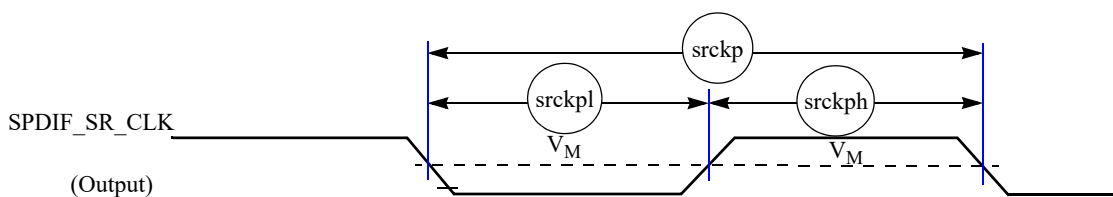

Figure 29. SPDIF_SR_CLK timing diagram

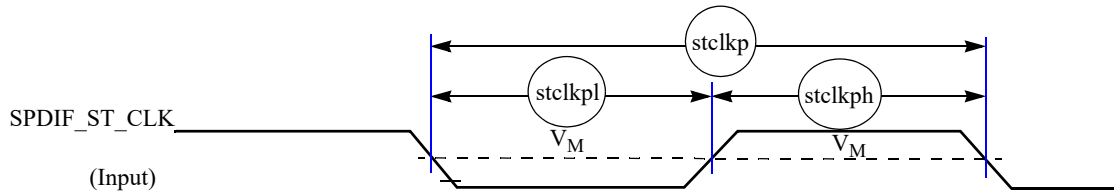

Figure 30. SPDIF_ST_CLK timing diagram

4.7 Analog

The following sections provide information about analog interfaces.

4.7.1 DCDC

Table 49 introduces the DCDC electrical specification.

Table 49. DCDC electrical specifications

Mode	Buck mode only, one output	Notes
Input voltage	3.3 V	$\pm 10\%$
Output voltage	1.1 V	Configurable 0.8 ~ 1.575 with 25 mV one step
Max loading	500 mA	—
Loading in low power modes	200 μ A ~ 30 mA	—
Efficiency	90% max	@150 mA
Low power mode	Open loop mode	Ripple is about 15 mV
Run mode	<ul style="list-style-type: none"> Always continuous mode Support discontinuous mode 	Configurable by register
Inductor	4.7 μ H	—
Capacitor	33 μ F	—
Over voltage protection	1.6 V	Detect VDDSOC, when the voltage is higher than 1.6 V, shutdown DCDC.
Over Current protection	1 A	Detect the peak current <ul style="list-style-type: none"> Run mode: when the current is larger than 1 A, shutdown DCDC. Stop mode: when the current is larger than 250 mA, stop charging the inductor.
Low battery detection	2.6 V	Detect the battery, when battery is lower than 2.6 V, shutdown DCDC.

4.7.2 A/D converter

This section introduces information about A/D converter.

Electrical characteristics

4.7.2.1 12-bit ADC electrical characteristics

The section provide information about 12-bit ADC electrical characteristics.

4.7.2.1.1 12-bit ADC operating conditions

Table 50. 12-bit ADC operating conditions

Characteristic	Conditions	Symb	Min	Typ ¹	Max	Unit	Comment
Supply voltage	Absolute	V_{DDA}	3.0	-	3.6	V	—
	Delta to VDD (VDD-VDDA) ²	ΔV_{DDA}	-100	0	100	mV	—
Ground voltage	Delta to VSS (VSS-VSSAD)	ΔV_{SSAD}	-100	0	100	mV	—
Ref Voltage High	—	V_{DDA}	1.13	V_{DDA}	V_{DDA}	V	—
Ref Voltage Low	—	V_{SS}	V_{SS}	V_{SS}	V_{SS}	V	—
Input Voltage	—	V_{ADIN}	V_{SS}	—	V_{DDA}	V	—
Input Capacitance	8/10/12 bit modes	C_{ADIN}	—	1.5	2	pF	—
Input Resistance	ADLPC=0, ADHSC=1	R_{ADIN}	—	5	7	kohms	—
	ADLPC=0, ADHSC=0		—	12.5	15	kohms	—
	ADLPC=1, ADHSC=0		—	25	30	kohms	—
Analog Source Resistance	12 bit mode $f_{ADCK} = 40\text{MHz}$ ADLSMP=0, ADSTS=10, ADHSC=1	R_{AS}	—	—	1	kohms	$T_{\text{samp}}=150\text{ ns}$
R_{AS} depends on Sample Time Setting (ADLSMP, ADSTS) and ADC Power Mode (ADHSC, ADLPC). See charts for Minimum Sample Time vs R_{AS}							
ADC Conversion Clock Frequency	ADLPC=0, ADHSC=1 12 bit mode	f_{ADCK}	4	—	40	MHz	—
	ADLPC=0, ADHSC=0 12 bit mode		4	—	30	MHz	—
	ADLPC=1, ADHSC=0 12 bit mode		4	—	20	MHz	—

¹ Typical values assume $V_{DDAD} = 3.0\text{ V}$, $\text{Temp} = 25^\circ\text{C}$, $f_{ADCK}=20\text{ MHz}$ unless otherwise stated. Typical values are for reference only and are not tested in production.

² DC potential differences

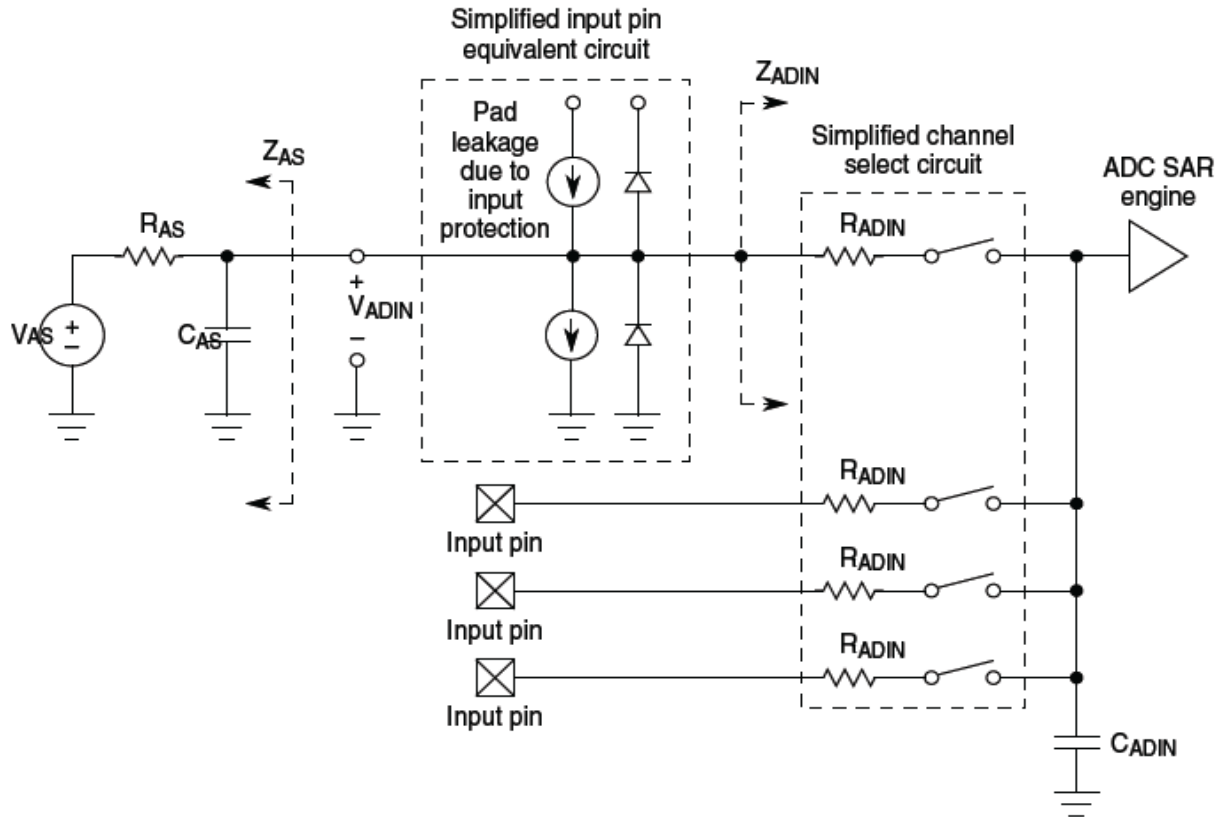

Figure 31. 12-bit ADC input impedance equivalency diagram

12-bit ADC characteristics

Table 51. 12-bit ADC characteristics ($V_{REFH} = V_{DDA}$, $V_{REFL} = V_{SSAD}$)

Characteristic	Conditions ¹	Symb	Min	Typ ²	Max	Unit	Comment
Supply Current	ADLPC=1, ADHSC=0	I_{DDA}	—	250	—	μA	ADLSMP = 0, ADSTS = 10, ADCO = 1
	ADLPC=0, ADHSC=0			350			
	ADLPC=0, ADHSC=1			400			
Supply Current	Stop, Reset, Module Off	I_{DDA}	—	0.01	0.8	μA	—
ADC Asynchronous Clock Source	ADHSC=0	f_{ADACK}	—	10	—	MHz	$t_{ADACK} = 1/f_{ADACK}$
	ADHSC=1			20			

Electrical characteristics

Table 51. 12-bit ADC characteristics ($V_{REFH} = V_{DDA}$, $V_{REFL} = V_{SSAD}$) (continued)

Characteristic	Conditions ¹	Symb	Min	Typ ²	Max	Unit	Comment
Sample Cycles	ADLSMP=0, ADSTS=00	Csamp	—	2	—	cycles	—
	ADLSMP=0, ADSTS=01			4			
	ADLSMP=0, ADSTS=10			6			
	ADLSMP=0, ADSTS=11			8			
	ADLSMP=1, ADSTS=00			12			
	ADLSMP=1, ADSTS=01			16			
	ADLSMP=1, ADSTS=10			20			
	ADLSMP=1, ADSTS=11			24			
Conversion Cycles	ADLSMP=0 ADSTS=00	Cconv	—	28	—	cycles	—
	ADLSMP=0 ADSTS=01			30			
	ADLSMP=0 ADSTS=10			32			
	ADLSMP=0 ADSTS=11			34			
	ADLSMP=1 ADSTS=00			38			
	ADLSMP=1 ADSTS=01			42			
	ADLSMP=1 ADSTS=10			46			
	ADLSMP=1, ADSTS=11			50			

Table 51. 12-bit ADC characteristics ($V_{REFH} = V_{DDA}$, $V_{REFL} = V_{SSAD}$) (continued)

Characteristic	Conditions ¹	Symb	Min	Typ ²	Max	Unit	Comment
Conversion Time	ADLSMP=0 ADSTS=00	Tconv	—	0.7	—	μs	Fadc = 40 MHz
	ADLSMP=0 ADSTS=01			0.75			
	ADLSMP=0 ADSTS=10			0.8			
	ADLSMP=0 ADSTS=11			0.85			
	ADLSMP=1 ADSTS=00			0.95			
	ADLSMP=1 ADSTS=01			1.05			
	ADLSMP=1 ADSTS=10			1.15			
	ADLSMP=1, ADSTS=11			1.25			
Total Unadjusted Error	12 bit mode	TUE	—	3.4	—	LSB 1 LSB = ($V_{REFH} - V_{REFL}$)/2 N	AVGE = 1, AVGS = 11
	10 bit mode			1.5			
	8 bit mode			1.2			
Differential Non-Linearity	12 bit mode	DNL	—	0.76	—	LSB	AVGE = 1, AVGS = 11
	10bit mode			0.36			
	8 bit mode			0.14			
Integral Non-Linearity	12 bit mode	INL	—	2.78	—	LSB	AVGE = 1, AVGS = 11
	10bit mode			0.61			
	8 bit mode			0.14			
Zero-Scale Error	12 bit mode	E _{ZS}	—	-1.14	—	LSB	AVGE = 1, AVGS = 11
	10bit mode			-0.25			
	8 bit mode			-0.19			
Full-Scale Error	12 bit mode	E _{FS}	—	-1.06	—	LSB	AVGE = 1, AVGS = 11
	10bit mode			-0.03			
	8 bit mode			-0.02			
Effective Number of Bits	12 bit mode	ENOB	10.1	10.7	—	Bits	AVGE = 1, AVGS = 11
Signal to Noise plus Distortion	See ENOB	SINAD	SINAD = 6.02 x ENOB + 1.76			dB	AVGE = 1, AVGS = 11

¹ All accuracy numbers assume the ADC is calibrated with $V_{REFH}=V_{DDAD}$

Electrical characteristics

² Typical values assume $V_{DDAD} = 3.0\text{ V}$, $\text{Temp} = 25^\circ\text{C}$, $F_{\text{adck}} = 20\text{ MHz}$ unless otherwise stated. Typical values are for reference only and are not tested in production.

NOTE

The ADC electrical spec is met with the calibration enabled configuration.

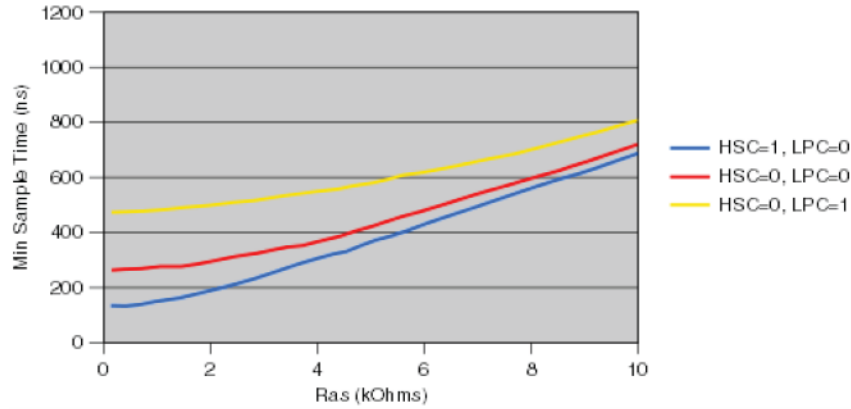

Figure 32. Minimum Sample Time Vs Ras (Cas = 2pF)

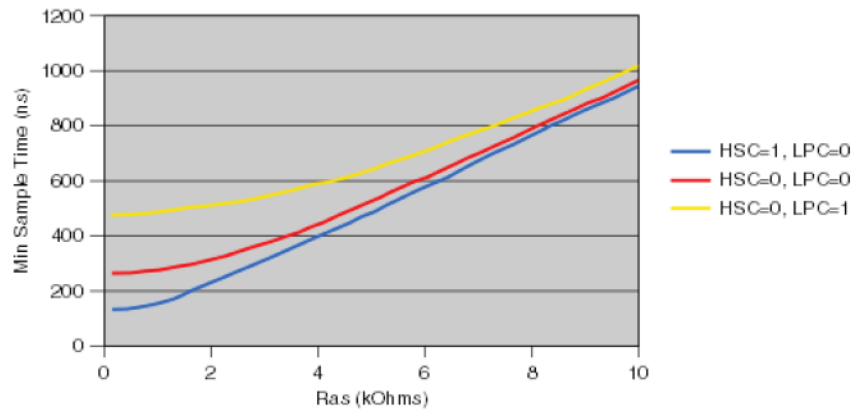

Figure 33. Minimum Sample Time Vs Ras (Cas = 5 pF)

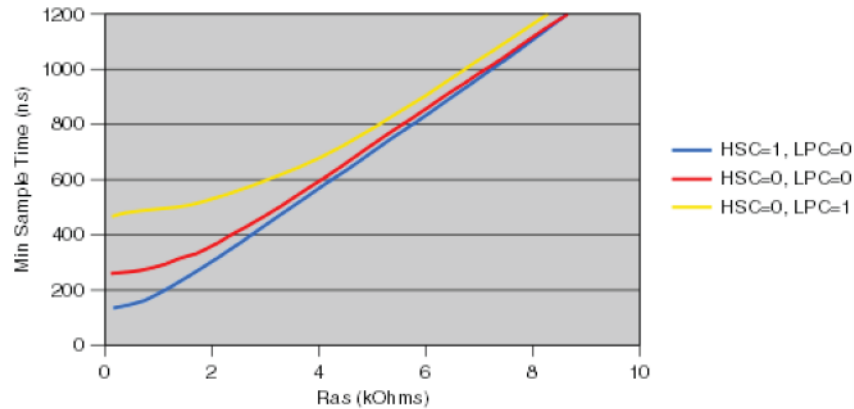

Figure 34. Minimum Sample Time Vs Ras (Cas = 10 pF)

4.7.3 ACMP

Table 52 lists the ACMP electrical specifications.

Table 52. Comparator and 6-bit DAC electrical specifications

Symbol	Description	Min.	Typ.	Max.	Unit	
V_{DD}	Supply voltage	3.0	—	3.6	V	
I_{DDHS}	Supply current, High-speed mode (EN = 1, PMODE = 1)	—	347	—	μ A	
I_{DDLs}	Supply current, Low-speed mode (EN = 1, PMODE = 0)	—	42	—	μ A	
V_{AIN}	Analog input voltage	V_{SS}	—	V_{DD}	V	
V_{AIO}	Analog input offset voltage	—	—	21	mV	
V_H	Analog comparator hysteresis ¹					mV
	• CR0[HYSTCTR] = 00	—	1	2		
	• CR0[HYSTCTR] = 01	—	21	54		
	• CR0[HYSTCTR] = 10	—	42	108		
	• CR0[HYSTCTR] = 11	—	64	184		
V_{CMPOH}	Output high	$V_{DD} - 0.5$	—	—	V	
V_{CMPOI}	Output low	—	—	0.5	V	
t_{DHS}	Propagation delay, high-speed mode (EN = 1, PMODE = 1) ²	—	25	40	ns	
t_{DLS}	Propagation delay, low-speed mode (EN = 1, PMODE = 0) ²	—	50	90	ns	
t_{DInit}	Analog comparator initialization delay ³	—	1.5	—	μ s	
I_{DAC6b}	6-bit DAC current adder (enabled)	—	5	—	μ A	

Electrical characteristics

Table 52. Comparator and 6-bit DAC electrical specifications (continued)

Symbol	Description	Min.	Typ.	Max.	Unit
R_{DAC6b}	6-bit DAC reference inputs	—	V_{DD}	—	V
INL_{DAC6b}	6-bit DAC integral non-linearity	-0.3	—	0.3	LSB ⁴
DNL_{DAC6b}	6-bit DAC differential non-linearity	-0.15	—	0.15	LSB ⁴

¹ Typical hysteresis is measured with input voltage range limited to 0.7 to $V_{DD} - 0.7$ V in high speed mode.

² Signal swing is 100 mV.

³ Comparator initialization delay is defined as the time between software writes to the enable comparator module and the comparator output setting to a stable level.

⁴ 1 LSB = $V_{reference} / 64$

4.8 Communication interfaces

The following sections provide the information about communication interfaces.

4.8.1 LPSPI timing parameters

The Low Power Serial Peripheral Interface (LPSPI) provides a synchronous serial bus with master and slave operations. Many of the transfer attributes are programmable. The following tables provide timing characteristics for classic LPSPI timing modes.

All timing is shown with respect to 20% V_{DD} and 80% V_{DD} thresholds, unless noted, as well as input signal transitions of 3 ns and a 30 pF maximum load on all LPSPI pins.

Table 53. LPSPI Master mode timing

Number	Symbol	Description	Min.	Max.	Units	Note
1	f_{SCK}	Frequency of operation	—	$f_{periph} / 2$	Hz	¹
2	t_{SCK}	SCK period	$2 \times t_{periph}$	—	ns	²
3	t_{Lead}	Enable lead time	1	—	t_{periph}	—
4	t_{Lag}	Enable lag time	1	—	t_{periph}	—
5	t_{WSCK}	Clock (SCK) high or low time	$t_{SCK} / 2 - 3$	—	ns	—
6	t_{SU}	Data setup time (inputs)	10	—	ns	—
7	t_{HI}	Data hold time (inputs)	2	—	ns	—
8	t_V	Data valid (after SCK edge)	—	8	ns	—
9	t_{HO}	Data hold time (outputs)	0	—	ns	—

¹ Absolute maximum frequency of operation (f_{op}) is 30 MHz. The clock driver in the LPSPI module for f_{periph} must be guaranteed this limit is not exceeded.

² $t_{periph} = 1 / f_{periph}$

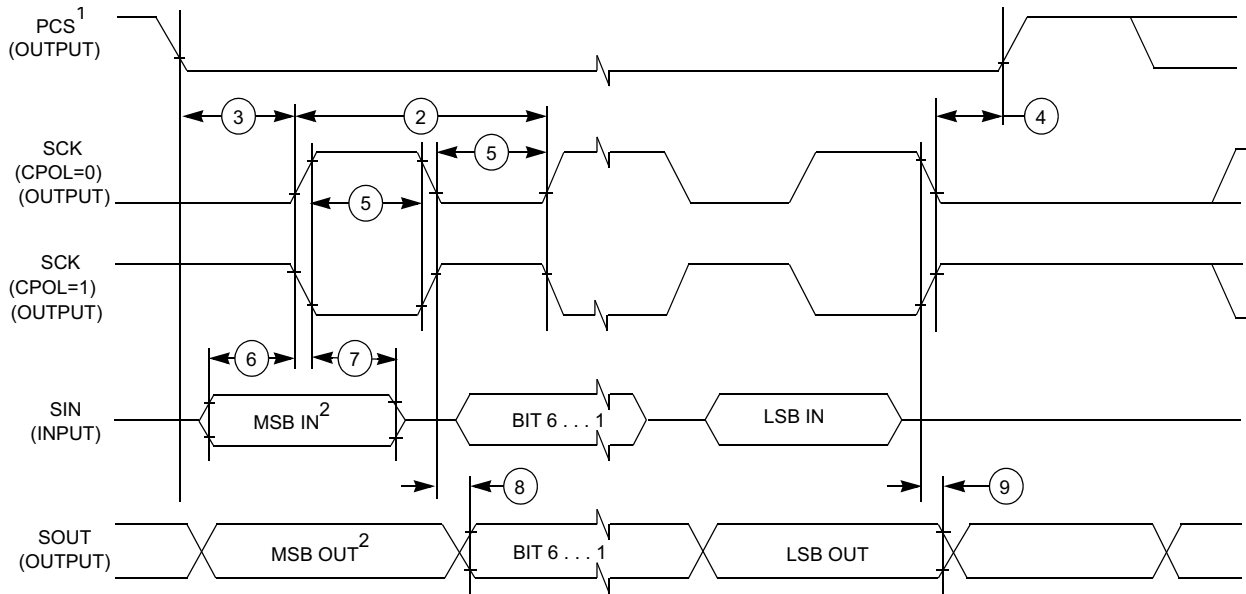

- 1. If configured as an output.
- 2. LSBF = 0. For LSBF = 1, bit order is LSB, bit 1, ..., bit 6, MSB.

Figure 35. LPSPI Master mode timing (CPHA = 0)

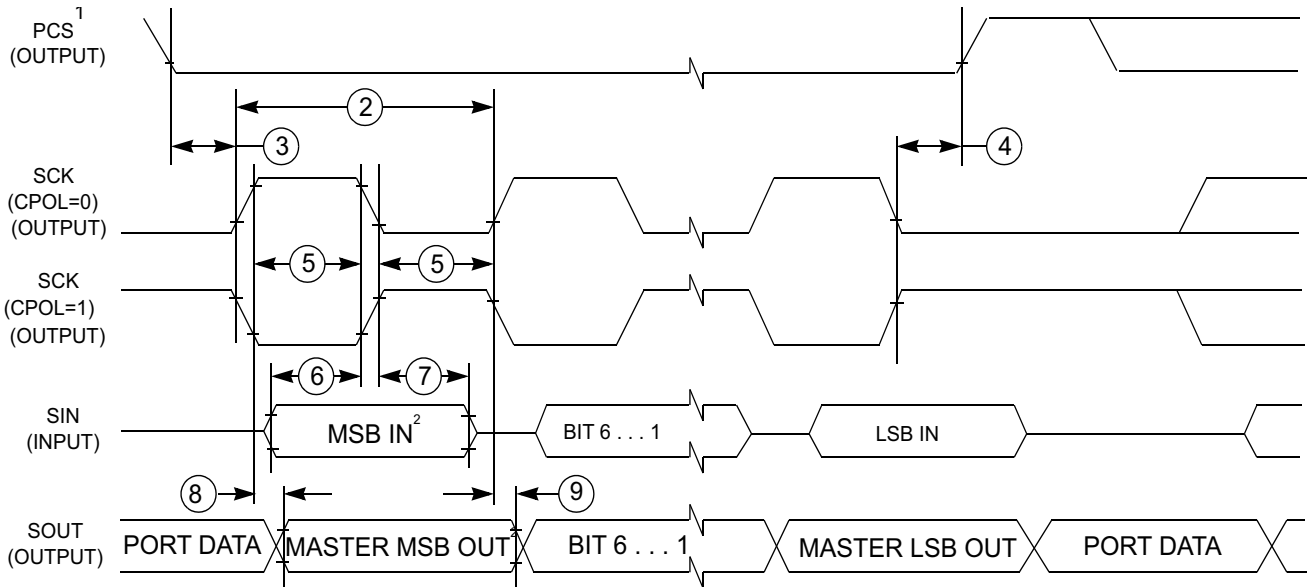

- 1. If configured as output
- 2. LSBF = 0. For LSBF = 1, bit order is LSB, bit 1, ..., bit 6, MSB.

Figure 36. LPSPI Master mode timing (CPHA = 1)

Table 54. LPSPI Slave mode timing

Number	Symbol	Description	Min.	Max.	Units	Note
1	f_{SCK}	Frequency of operation	0	$f_{periph} / 2$	Hz	1
2	t_{SCK}	SCK period	$2 \times t_{periph}$	—	ns	2
3	t_{Lead}	Enable lead time	1	—	t_{periph}	—
4	t_{Lag}	Enable lag time	1	—	t_{periph}	—
5	t_{WSCK}	Clock (SCK) high or low time	$t_{SCK} / 2 - 5$	—	ns	—
6	t_{SU}	Data setup time (inputs)	2.7	—	ns	—
7	t_{HI}	Data hold time (inputs)	3.8	—	ns	—
8	t_a	Slave access time	—	t_{periph}	ns	3
9	t_{dis}	Slave MISO disable time	—	t_{periph}	ns	4
10	t_v	Data valid (after SCK edge)	—	14.5	ns	—
11	t_{HO}	Data hold time (outputs)	0	—	ns	—

¹ Absolute maximum frequency of operation (fop) is 30 MHz. The clock driver in the LPSPI module for f_{periph} must be guaranteed this limit is not exceeded.

² $t_{periph} = 1 / f_{periph}$

³ Time to data active from high-impedance state

⁴ Hold time to high-impedance state

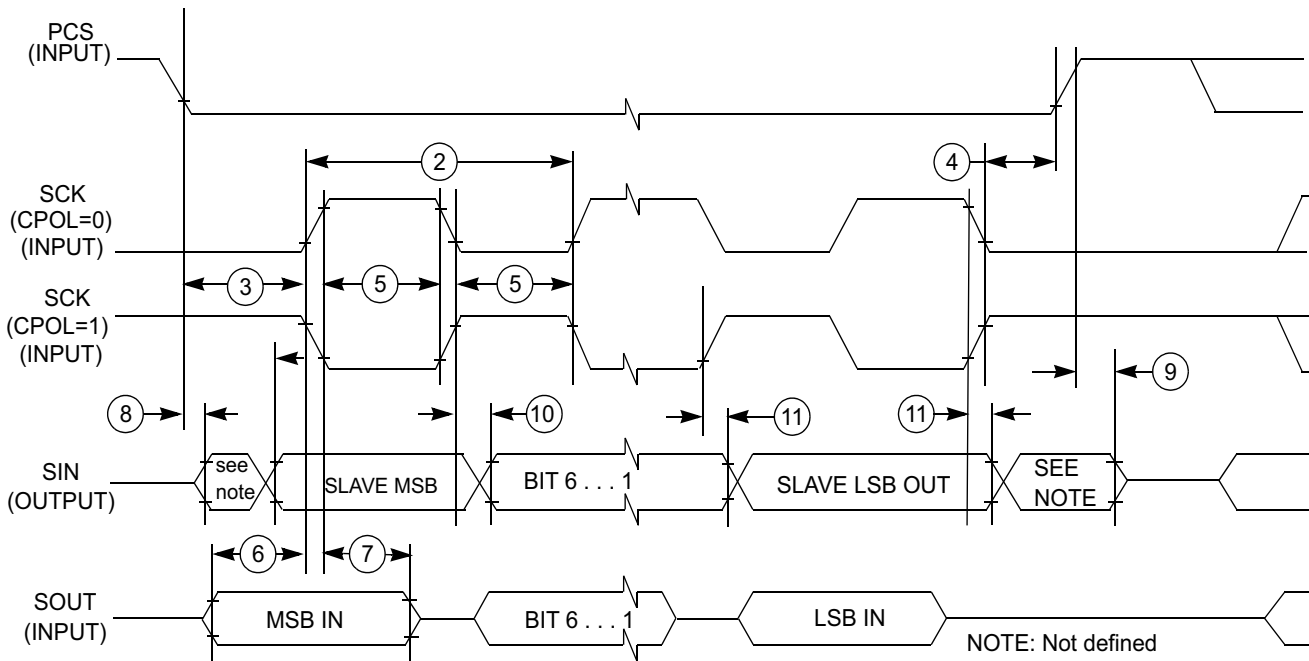

Figure 37. LPSPI Slave mode timing (CPHA = 0)

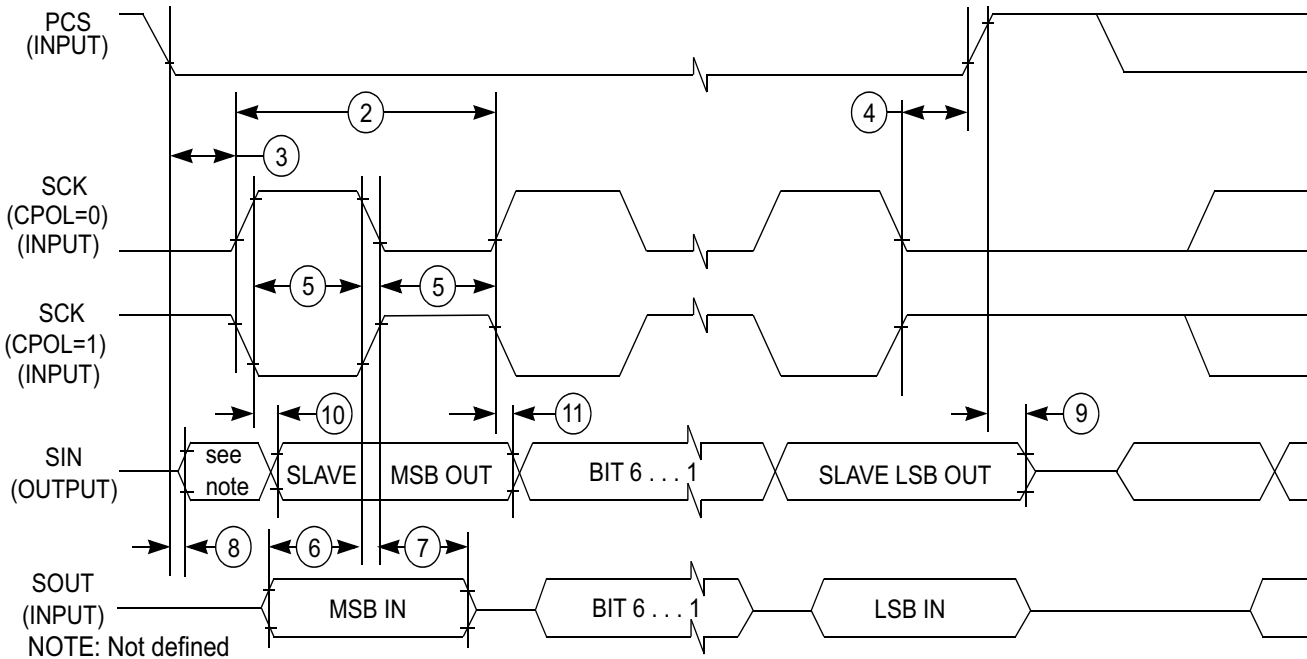

Figure 38. LPSPI Slave mode timing (CPHA = 1)

4.8.2 LPI2C module timing parameters

This section describes the timing parameters of the LPI2C module.

Table 55. LPI2C module timing parameters

Symbol	Description		Min	Max	Unit	Notes
f_{SCL}	SCL clock frequency	Standard mode (Sm)	0	100	kHz	1, 2
		Fast mode (Fm)	0	400		
		Fast mode Plus (Fm+)	0	1000		
		Ultra Fast mode (UFm)	0	5000		
		High speed mode (Hs-mode)	0	3400		

¹ Hs-mode is only supported in slave mode.

² See General switching specifications.

4.8.3 Ultra High Speed SD/SDIO/MMC Host Interface (uSDHC) AC timing

This section describes the electrical information of the uSDHC, which includes SD/eMMC4.3 (Single Data Rate) timing, eMMC4.4/4.41/4.5 (Dual Data Rate) timing and SDR104/50(SD3.0) timing.

4.8.3.1 SD/eMMC4.3 (single data rate) AC timing

Figure 39 depicts the timing of SD/eMMC4.3, and Table 56 lists the SD/eMMC4.3 timing characteristics.

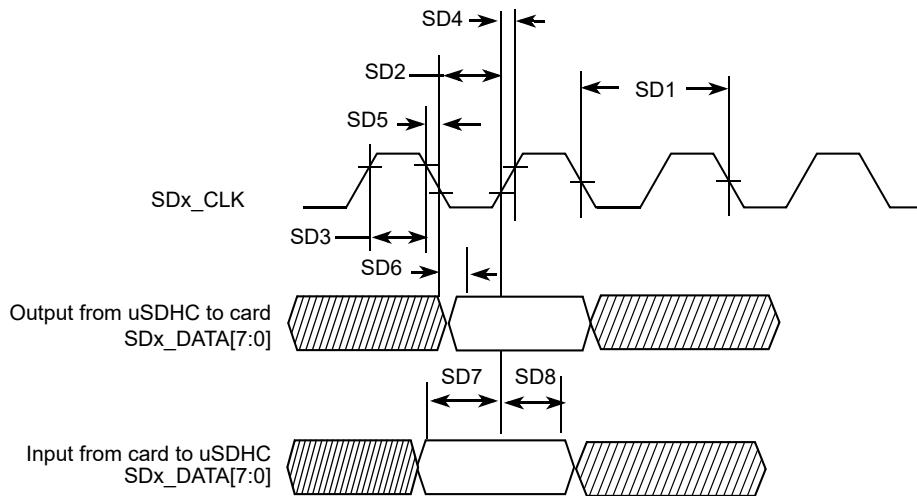

Figure 39. SD/eMMC4.3 timing

Table 56. SD/eMMC4.3 interface timing specification

ID	Parameter	Symbols	Min	Max	Unit
Card Input Clock					
SD1	Clock Frequency (Low Speed)	f_{PP}^1	0	400	kHz
	Clock Frequency (SD/SDIO Full Speed/High Speed)	f_{PP}^2	0	25/50	MHz
	Clock Frequency (MMC Full Speed/High Speed)	f_{PP}^3	0	20/52	MHz
	Clock Frequency (Identification Mode)	f_{OD}	100	400	kHz
SD2	Clock Low Time	t_{WL}	7	—	ns
SD3	Clock High Time	t_{WH}	7	—	ns
SD4	Clock Rise Time	t_{TLH}	—	3	ns
SD5	Clock Fall Time	t_{THL}	—	3	ns
uSDHC Output/Card Inputs SD_CMD, SDx_DATAx (Reference to CLK)					
SD6	uSDHC Output Delay	t_{OD}	-6.6	3.6	ns

Table 56. SD/eMMC4.3 interface timing specification (continued)

ID	Parameter	Symbols	Min	Max	Unit
uSDHC Input/Card Outputs SD_CMD, SDx_DATAx (Reference to CLK)					
SD7	uSDHC Input Setup Time	t_{ISU}	2.5	—	ns
SD8	uSDHC Input Hold Time ⁴	t_{IH}	1.5	—	ns

¹ In low speed mode, card clock must be lower than 400 kHz, voltage ranges from 2.7 to 3.6 V.

² In normal (full) speed mode for SD/SDIO card, clock frequency can be any value between 0–25 MHz. In high-speed mode, clock frequency can be any value between 0–50 MHz.

³ In normal (full) speed mode for MMC card, clock frequency can be any value between 0–20 MHz. In high-speed mode, clock frequency can be any value between 0–52 MHz.

⁴ To satisfy hold timing, the delay difference between clock input and cmd/data input must not exceed 2 ns.

4.8.3.2 eMMC4.4/4.41 (dual data rate) AC timing

Figure 40 depicts the timing of eMMC4.4/4.41. Table 57 lists the eMMC4.4/4.41 timing characteristics. Be aware that only DATA is sampled on both edges of the clock (not applicable to CMD).

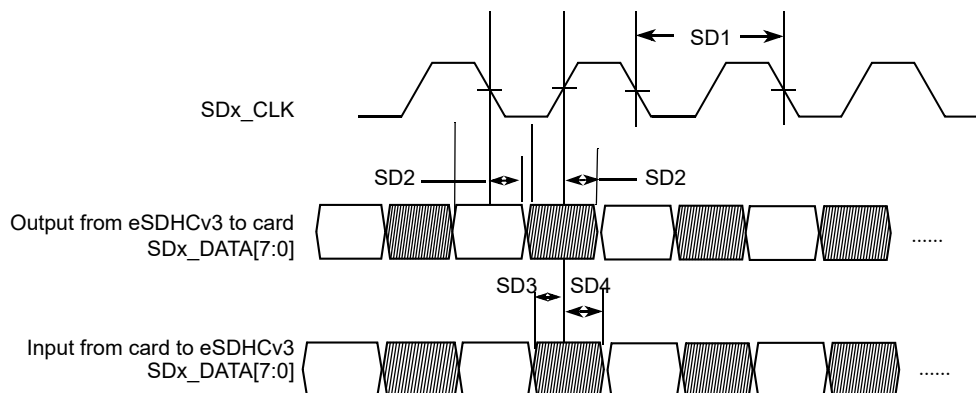

Figure 40. eMMC4.4/4.41 timing

Table 57. eMMC4.4/4.41 interface timing specification

ID	Parameter	Symbols	Min	Max	Unit
Card Input Clock					
SD1	Clock Frequency (eMMC4.4/4.41 DDR)	f_{PP}	0	52	MHz
SD1	Clock Frequency (SD3.0 DDR)	f_{PP}	0	50	MHz
uSDHC Output / Card Inputs SD_CMD, SDx_DATAx (Reference to CLK)					
SD2	uSDHC Output Delay	t_{OD}	2.5	7.1	ns
uSDHC Input / Card Outputs SD_CMD, SDx_DATAx (Reference to CLK)					
SD3	uSDHC Input Setup Time	t_{ISU}	1.7	—	ns
SD4	uSDHC Input Hold Time	t_{IH}	1.5	—	ns

4.8.3.3 SDR50/SDR104 AC timing

Figure 41 depicts the timing of SDR50/SDR104, and Table 58 lists the SDR50/SDR104 timing characteristics.

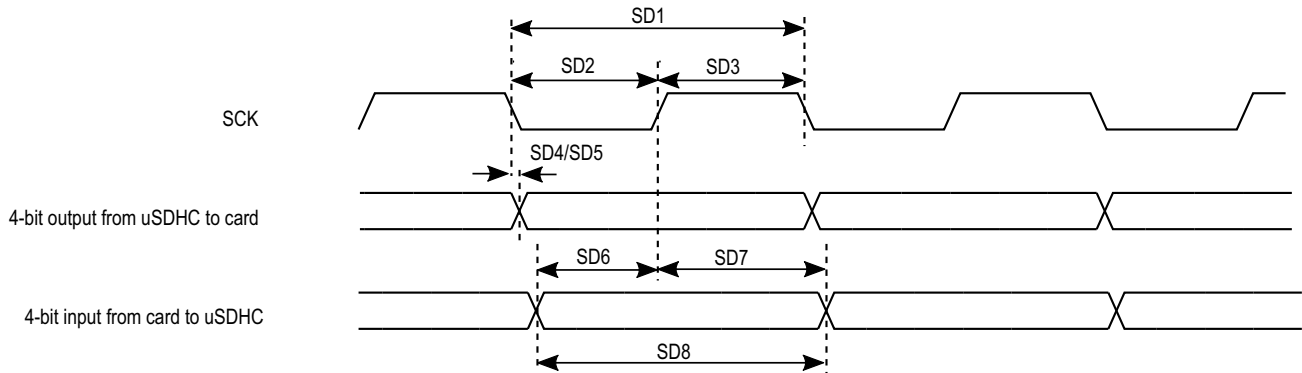

Figure 41. SDR50/SDR104 timing

Table 58. SDR50/SDR104 interface timing specification

ID	Parameter	Symbols	Min	Max	Unit
Card Input Clock					
SD1	Clock Frequency Period	t_{CLK}	5.0	—	ns
SD2	Clock Low Time	t_{CL}	$0.46 \times t_{CLK}$	$0.54 \times t_{CLK}$	ns
SD3	Clock High Time	t_{CH}	$0.46 \times t_{CLK}$	$0.54 \times t_{CLK}$	ns
uSDHC Output/Card Inputs SD_CMD, SDx_DATAx in SDR50 (Reference to CLK)					
SD4	uSDHC Output Delay	t_{OD}	-3	1	ns
uSDHC Output/Card Inputs SD_CMD, SDx_DATAx in SDR104 (Reference to CLK)					
SD5	uSDHC Output Delay	t_{OD}	-1.6	1	ns
uSDHC Input/Card Outputs SD_CMD, SDx_DATAx in SDR50 (Reference to CLK)					
SD6	uSDHC Input Setup Time	t_{ISU}	2.5	—	ns
SD7	uSDHC Input Hold Time	t_{IH}	1.5	—	ns
uSDHC Input/Card Outputs SD_CMD, SDx_DATAx in SDR104 (Reference to CLK)¹					
SD8	Card Output Data Window	t_{ODW}	$0.5 \times t_{CLK}$	—	ns

¹Data window in SDR104 mode is variable.

4.8.3.4 HS200 mode timing

Figure 42 depicts the timing of HS200 mode, and Table 59 lists the HS200 timing characteristics.

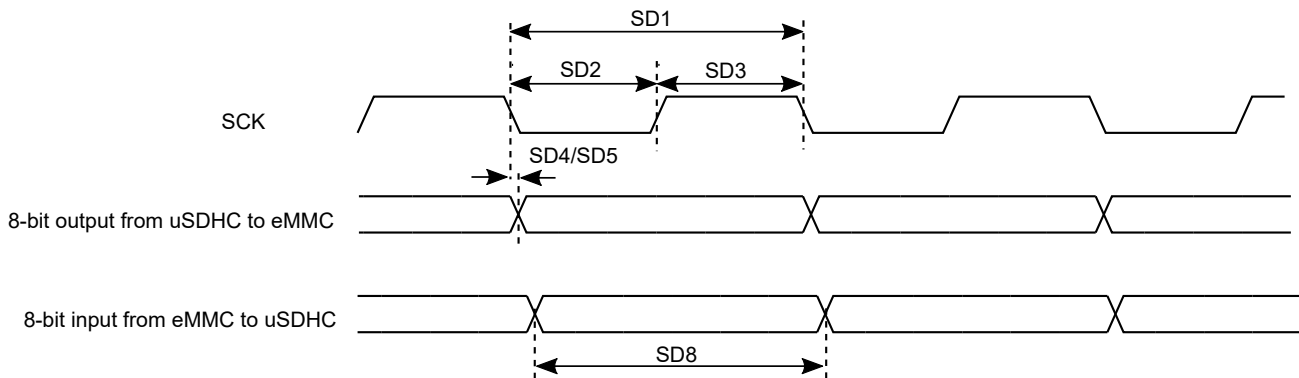

Figure 42. HS200 mode timing

Table 59. HS200 interface timing specification

ID	Parameter	Symbols	Min	Max	Unit
Card Input Clock					
SD1	Clock Frequency Period	t_{CLK}	5.0	—	ns
SD2	Clock Low Time	t_{CL}	$0.46 \times t_{CLK}$	$0.54 \times t_{CLK}$	ns
SD3	Clock High Time	t_{CH}	$0.46 \times t_{CLK}$	$0.54 \times t_{CLK}$	ns
uSDHC Output/Card Inputs SD_CMD, SDx_DATAx in HS200 (Reference to CLK)					
SD5	uSDHC Output Delay	t_{OD}	-1.6	0.74	ns
uSDHC Input/Card Outputs SD_CMD, SDx_DATAx in HS200 (Reference to CLK)¹					
SD8	Card Output Data Window	t_{ODW}	$0.5 \times t_{CLK}$	—	ns

¹HS200 is for 8 bits while SDR104 is for 4 bits.

4.8.3.5 Bus operation condition for 3.3 V and 1.8 V signaling

Signaling level of SD/eMMC4.3 and eMMC4.4/4.41 modes is 3.3 V. Signaling level of SDR104/SDR50 mode is 1.8 V. The DC parameters for the NVCC_SD1 supply are identical to those shown in Table 22, "Single voltage GPIO DC parameters," on page 30.

4.8.4 Ethernet controller (ENET) AC electrical specifications

The following timing specs are defined at the chip I/O pin and must be translated appropriately to arrive at timing specs/constraints for the physical interface.

4.8.4.1 ENET MII mode timing

This subsection describes MII receive, transmit, asynchronous inputs, and serial management signal timings.

4.8.4.1.1 MII receive signal timing (ENET_RX_DATA3,2,1,0, ENET_RX_EN, ENET_RX_ER, and ENET_RX_CLK)

The receiver functions correctly up to an ENET_RX_CLK maximum frequency of 25 MHz + 1%. There is no minimum frequency requirement. Additionally, the processor clock frequency must exceed twice the ENET_RX_CLK frequency.

Figure 43 shows MII receive signal timings. Table 60 describes the timing parameters (M1–M4) shown in the figure.

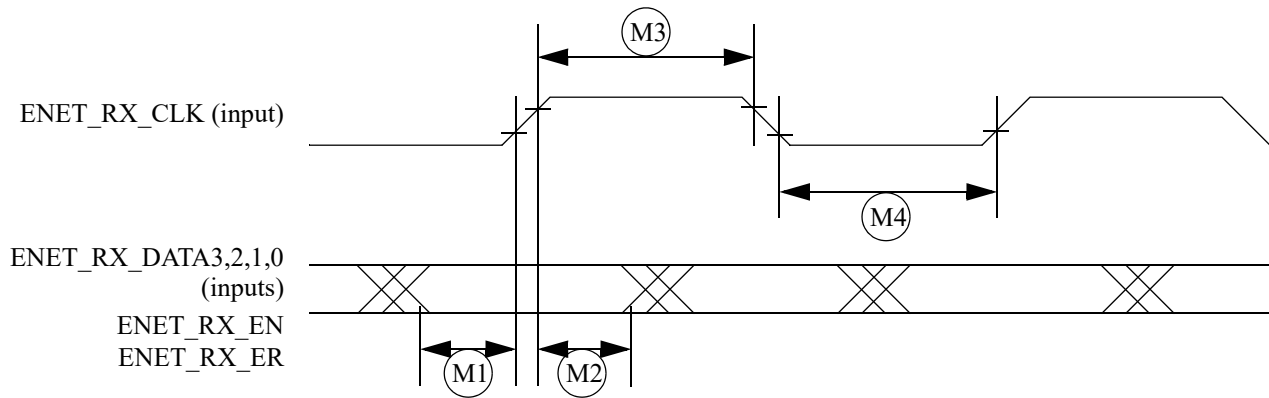

Figure 43. MII receive signal timing diagram

Table 60. MII receive signal timing

ID	Characteristic ¹	Min.	Max.	Unit
M1	ENET_RX_DATA3,2,1,0, ENET_RX_EN, ENET_RX_ER to ENET_RX_CLK setup	5	—	ns
M2	ENET_RX_CLK to ENET_RX_DATA3,2,1,0, ENET_RX_EN, ENET_RX_ER hold	5	—	ns
M3	ENET_RX_CLK pulse width high	35%	65%	ENET_RX_CLK period
M4	ENET_RX_CLK pulse width low	35%	65%	ENET_RX_CLK period

¹ ENET_RX_EN, ENET_RX_CLK, and ENET0_RXD0 have the same timing in 10 Mbps 7-wire interface mode.

4.8.4.1.2 MII transmit signal timing (ENET_TX_DATA3,2,1,0, ENET_TX_EN, ENET_TX_ER, and ENET_TX_CLK)

The transmitter functions correctly up to an ENET_TX_CLK maximum frequency of 25 MHz + 1%. There is no minimum frequency requirement. Additionally, the processor clock frequency must exceed twice the ENET_TX_CLK frequency.

Figure 44 shows MII transmit signal timings. Table 61 describes the timing parameters (M5–M8) shown in the figure.

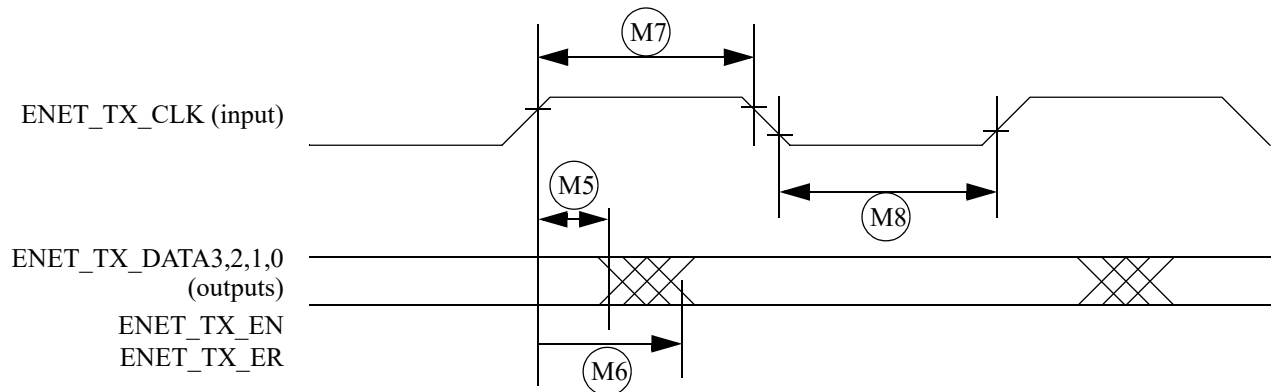

Figure 44. MII transmit signal timing diagram

Table 61. MII transmit signal timing

ID	Characteristic ¹	Min.	Max.	Unit
M5	ENET_TX_CLK to ENET_TX_DATA3,2,1,0, ENET_TX_EN, ENET_TX_ER invalid	5	—	ns
M6	ENET_TX_CLK to ENET_TX_DATA3,2,1,0, ENET_TX_EN, ENET_TX_ER valid	—	20	ns
M7	ENET_TX_CLK pulse width high	35%	65%	ENET_TX_CLK period
M8	ENET_TX_CLK pulse width low	35%	65%	ENET_TX_CLK period

¹ ENET_TX_EN, ENET_TX_CLK, and ENET0_TXD0 have the same timing in 10-Mbps 7-wire interface mode.

4.8.4.1.3 MII asynchronous inputs signal timing (ENET_CRS and ENET_COL)

Figure 45 shows MII asynchronous input timings. Table 62 describes the timing parameter (M9) shown in the figure.

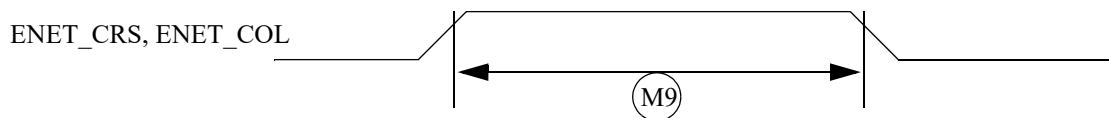

Figure 45. MII async inputs timing diagram

Table 62. MII asynchronous inputs signal timing

ID	Characteristic	Min.	Max.	Unit
M9 ¹	ENET_CRS to ENET_COL minimum pulse width	1.5	—	ENET_TX_CLK period

¹ ENET_COL has the same timing in 10-Mbit 7-wire interface mode.

4.8.4.1.4 MII serial management channel timing (ENET_MDIO and ENET_MDC)

The MDC frequency is designed to be equal to or less than 2.5 MHz to be compatible with the IEEE 802.3 MII specification. However the ENET can function correctly with a maximum MDC frequency of 15 MHz.

Figure 46 shows MII asynchronous input timings. Table 63 describes the timing parameters (M10–M15) shown in the figure.

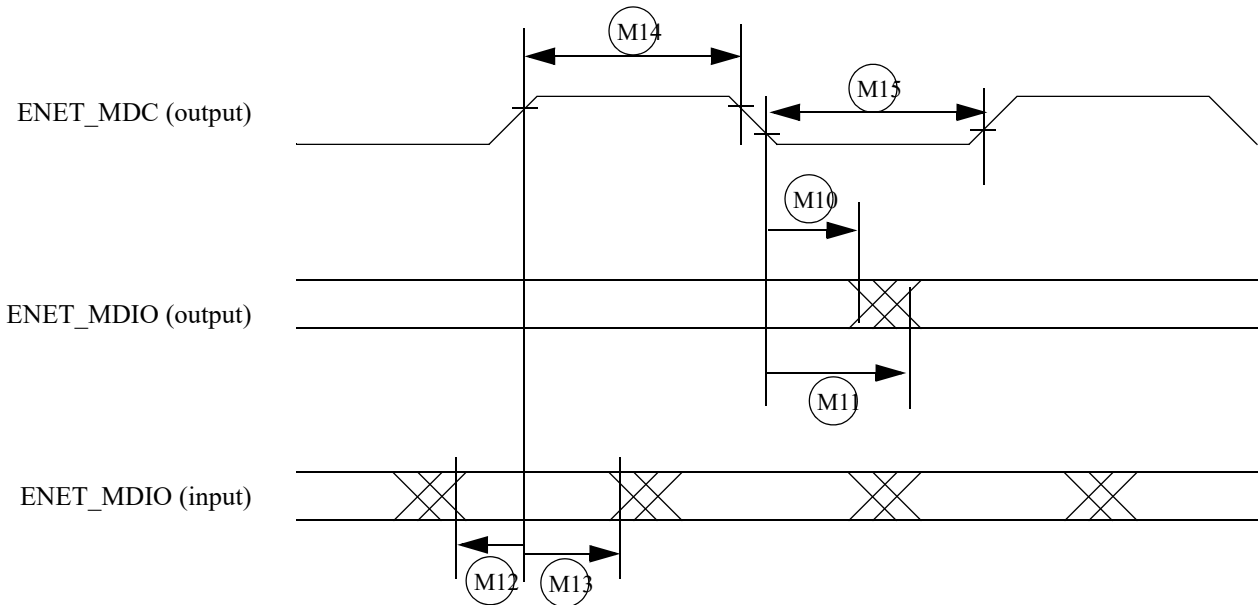

Figure 46. MII serial management channel timing diagram

Table 63. MII serial management channel timing

ID	Characteristic	Min.	Max.	Unit
M10	ENET_MDC falling edge to ENET_MDIO output invalid (min. propagation delay)	0	—	ns
M11	ENET_MDC falling edge to ENET_MDIO output valid (max. propagation delay)	—	5	ns
M12	ENET_MDIO (input) to ENET_MDC rising edge setup	18	—	ns
M13	ENET_MDIO (input) to ENET_MDC rising edge hold	0	—	ns
M14	ENET_MDC pulse width high	40%	60%	ENET_MDC period
M15	ENET_MDC pulse width low	40%	60%	ENET_MDC period

4.8.4.2 RMII mode timing

In RMII mode, ENET_CLK is used as the REF_CLK, which is a 50 MHz ± 50 ppm continuous reference clock. ENET_RX_EN is used as the ENET_RX_EN in RMII. Other signals under RMII mode include ENET_TX_EN, ENET_TX_DATA[1:0], ENET_RX_DATA[1:0] and ENET_RX_ER.

Figure 47 shows RMI mode timings. Table 64 describes the timing parameters (M16–M21) shown in the figure.

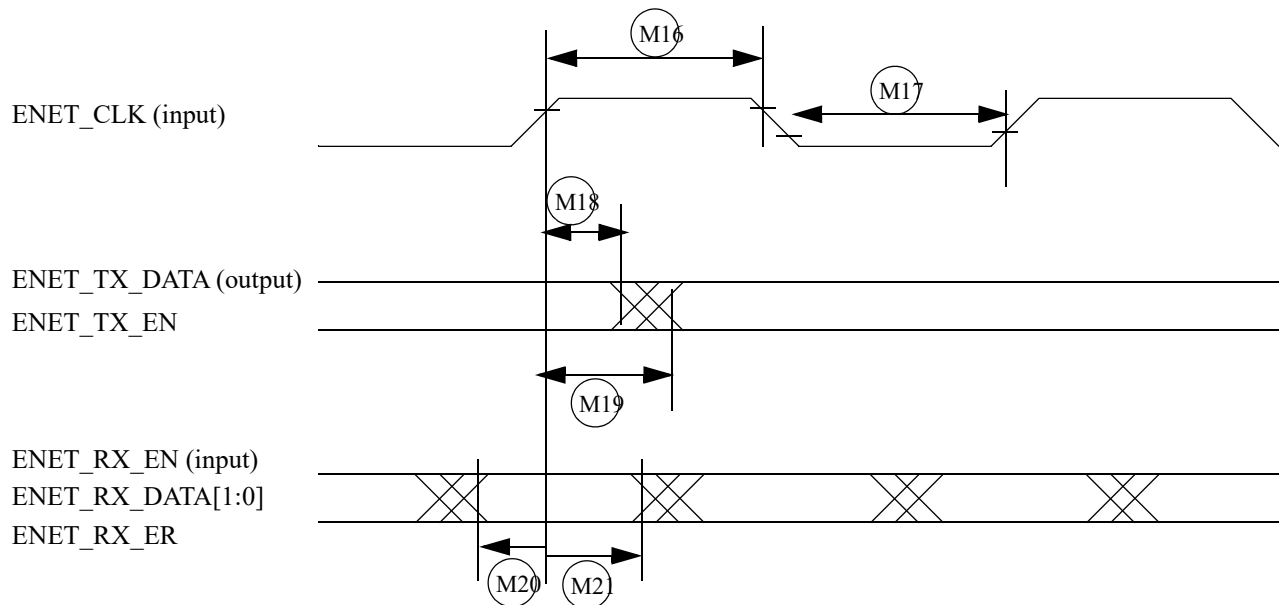

Figure 47. RMI mode signal timing diagram

Table 64. RMI signal timing

ID	Characteristic	Min.	Max.	Unit
M16	ENET_CLK pulse width high	35%	65%	ENET_CLK period
M17	ENET_CLK pulse width low	35%	65%	ENET_CLK period
M18	ENET_CLK to ENET0_TXD[1:0], ENET_TX_DATA invalid	4	—	ns
M19	ENET_CLK to ENET0_TXD[1:0], ENET_TX_DATA valid	—	13	ns
M20	ENET_RX_DATAD[1:0], ENET_RX_EN(ENET_RX_EN), ENET_RX_ER to ENET_CLK setup	2	—	ns
M21	ENET_CLK to ENET_RX_DATAD[1:0], ENET_RX_EN, ENET_RX_ER hold	2	—	ns

4.8.5 Flexible Controller Area Network (FLEXCAN) AC electrical specifications

Please refer to [Section 4.3.2.1, General purpose I/O AC parameters](#).

4.8.6 LPUART electrical specifications

Please refer to [Section 4.3.2.1, General purpose I/O AC parameters](#).

4.8.7 USB PHY parameters

This section describes the USB-OTG PHY parameters.

The USB PHY meets the electrical compliance requirements defined in the Universal Serial Bus Revision 2.0 OTG with the following amendments.

- USB ENGINEERING CHANGE NOTICE
 - Title: 5V Short Circuit Withstand Requirement Change
 - Applies to: Universal Serial Bus Specification, Revision 2.0
- Errata for USB Revision 2.0 April 27, 2000 as of 12/7/2000
- USB ENGINEERING CHANGE NOTICE
 - Title: Pull-up/Pull-down resistors
 - Applies to: Universal Serial Bus Specification, Revision 2.0
- USB ENGINEERING CHANGE NOTICE
 - Title: Suspend Current Limit Changes
 - Applies to: Universal Serial Bus Specification, Revision 2.0
- USB ENGINEERING CHANGE NOTICE
 - Title: USB 2.0 Phase Locked SOFs
 - Applies to: Universal Serial Bus Specification, Revision 2.0
- On-The-Go and Embedded Host Supplement to the USB Revision 2.0 Specification
 - Revision 2.0 plus errata and ecn June 4, 2010
- Battery Charging Specification (available from USB-IF)
 - Revision 1.2, December 7, 2010
 - Portable device only

4.9 Timers

This section provide information on timers.

4.9.1 Pulse Width Modulator (PWM) characteristics

This section describes the electrical information of the PWM.

Table 65. PWM timing parameters

Parameter	Symbo	Min	Typ	Max	Unit
PWM Clock Frequency	—	80	—	120	MHz
Power-up Time	t_{pu}	—	25	—	μ s

4.9.2 Quad timer timing

[Table 66](#) listed the timing parameters.

Table 66. Quad Timer Timing

Characteristic	Symbo	Min ¹	Max	Unit	See Figure
Timer input period	T_{IN}	$2T + 6$	—	ns	
Timer input high/low period	T_{INHL}	$1T + 3$	—	ns	
Timer output period	T_{OUT}	33	—	ns	
Timer output high/low period	T_{OUTHHL}	16.7	—	ns	

¹ T = clock cycle. For 60 MHz operation, T = 16.7 ns.

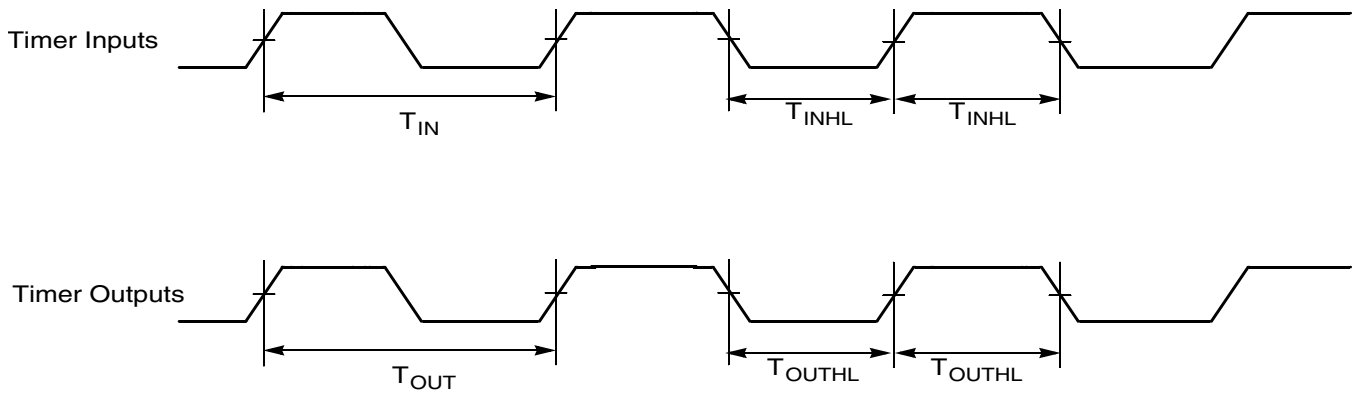

Figure 48. Quad timer timing

5 Boot mode configuration

This section provides information on boot mode configuration pins allocation and boot devices interfaces allocation.

5.1 Boot mode configuration pins

Table 67 provides boot options, functionality, fuse values, and associated pins. Several input pins are also sampled at reset and can be used to override fuse values, depending on the value of BT_FUSE_SEL fuse. The boot option pins are in effect when BT_FUSE_SEL fuse is '0' (cleared, which is the case for an unblown fuse). For detailed boot mode options configured by the boot mode pins, see the i.MX RT1020 Fuse Map document and the System Boot chapter in *i.MX RT1020 Reference Manual (IMXRT1020RM)*.

Table 67. Fuses and associated pins used for boot

Pad	Default setting on reset	eFuse name	Details
GPIO_EMC_16	100 K pull-down	src.BOOT_MODE0	
GPIO_EMC_17	100 K pull-down	src.BOOT_MODE1	
GPIO_EMC_18	100 K pull-down	src.BT_CFG[0]	Boot Options, Pin value overrides fuse settings for BT_FUSE_SEL = '0'. Signal Configuration as Fuse Override Input at Power Up. These are special I/O lines that control the boot up configuration during product development. In production, the boot configuration can be controlled by fuses.
GPIO_EMC_19	100 K pull-down	src.BT_CFG[1]	
GPIO_EMC_20	100 K pull-down	src.BT_CFG[2]	
GPIO_EMC_21	100 K pull-down	src.BT_CFG[3]	
GPIO_EMC_22	100 K pull-down	src.BT_CFG[4]	
GPIO_EMC_23	100 K pull-down	src.BT_CFG[5]	
GPIO_EMC_24	100 K pull-down	src.BT_CFG[6]	
GPIO_EMC_25	100 K pull-down	src.BT_CFG[7]	
GPIO_EMC_26	100 K pull-down	src.BT_CFG[8]	
GPIO_EMC_27	100 K pull-down	src.BT_CFG[9]	

5.2 Boot device interface allocation

The following tables list the interfaces that can be used by the boot process in accordance with the specific boot mode configuration. The tables also describe the interface's specific modes and IOMUXC allocation, which are configured during boot when appropriate.

Table 68. Boot trough NAND

PAD Name	IO Function	ALT	Comments
GPIO_EMC_00	semc.DATA[0]	ALT 0	—
GPIO_EMC_01	semc.DATA[1]	ALT 0	—
GPIO_EMC_02	semc.DATA[2]	ALT 0	—
GPIO_EMC_03	semc.DATA[3]	ALT 0	—
GPIO_EMC_04	semc.DATA[4]	ALT 0	—

Table 68. Boot trough NAND

GPIO_EMC_05	semc.DATA[5]	ALT 0	—
GPIO_EMC_06	semc.DATA[6]	ALT 0	—
GPIO_EMC_07	semc.DATA[7]	ALT 0	—
GPIO_EMC_32	semc.DATA[8]	ALT 0	—
GPIO_EMC_33	semc.DATA[9]	ALT 0	—
GPIO_EMC_34	semc.DATA[10]	ALT 0	—
GPIO_EMC_35	semc.DATA[11]	ALT 0	—
GPIO_EMC_36	semc.DATA[12]	ALT 0	—
GPIO_EMC_37	semc.DATA[13]	ALT 0	—
GPIO_EMC_38	semc.DATA[14]	ALT 0	—
GPIO_EMC_39	semc.DATA[15]	ALT 0	—
GPIO_EMC_25	semc.ADDR[9]	ALT 0	—
GPIO_EMC_26	semc.ADDR[11]	ALT 0	—
GPIO_EMC_27	semc.ADDR[12]	ALT 0	—
GPIO_EMC_14	semc.BA1	ALT 0	—
GPIO_EMC_40	semc.CSX[0]	ALT 0	—

Table 69. Boot trough NOR

PAD Name	IO Function	ALT	Comments
GPIO_EMC_00	semc.DATA[0]	ALT 0	—
GPIO_EMC_01	semc.DATA[1]	ALT 0	—
GPIO_EMC_02	semc.DATA[2]	ALT 0	—
GPIO_EMC_03	semc.DATA[3]	ALT 0	—
GPIO_EMC_04	semc.DATA[4]	ALT 0	—
GPIO_EMC_05	semc.DATA[5]	ALT 0	—
GPIO_EMC_06	semc.DATA[6]	ALT 0	—
GPIO_EMC_07	semc.DATA[7]	ALT 0	—
GPIO_EMC_32	semc.DATA[8]	ALT 0	—
GPIO_EMC_33	semc.DATA[9]	ALT 0	—
GPIO_EMC_34	semc.DATA[10]	ALT 0	—
GPIO_EMC_35	semc.DATA[11]	ALT 0	—
GPIO_EMC_36	semc.DATA[12]	ALT 0	—
GPIO_EMC_37	semc.DATA[13]	ALT 0	—

Table 69. Boot trough NOR

GPIO_EMC_38	semc.DATA[14]	ALT 0	—
GPIO_EMC_39	semc.DATA[15]	ALT 0	—
GPIO_EMC_16	semc.ADDR[0]	ALT 0	—
GPIO_EMC_17	semc.ADDR[1]	ALT 0	—
GPIO_EMC_18	semc.ADDR[2]	ALT 0	—
GPIO_EMC_19	semc.ADDR[3]	ALT 0	—
GPIO_EMC_20	semc.ADDR[4]	ALT 0	—
GPIO_EMC_21	semc.ADDR[5]	ALT 0	—
GPIO_EMC_22	semc.ADDR[6]	ALT 0	—
GPIO_EMC_23	semc.ADDR[7]	ALT 0	—
GPIO_EMC_26	semc.ADDR[11]	ALT 0	—
GPIO_EMC_27	semc.ADDR[12]	ALT 0	—
GPIO_EMC_13	semc.BA0	ALT 0	—
GPIO_EMC_14	semc.BA1	ALT 0	—
GPIO_EMC_40	semc.CSX[0]	ALT 0	—

Table 70. Boot through FlexSPI

PAD Name	IO Function	Mux Mode	Comments
GPIO_SD_B1_00	flexspi.B_DATA[3]	ALT 1	—
GPIO_SD_B1_03	flexspi.B_DATA[2]	ALT 1	—
GPIO_SD_B1_04	flexspi.B_DATA[1]	ALT 1	—
GPIO_SD_B1_02	flexspi.B_DATA[0]	ALT 1	—
GPIO_SD_B1_01	flexspi.B_SCLK	ALT 1	—
GPIO_SD_B0_05	flexspi.B_DQS	ALT 6	—
GPIO_SD_B0_04	flexspi.B_SS0_B	ALT 6	—
GPIO_SD_B0_01	flexspi.B_SS1_B	ALT 6	—
GPIO_SD_B1_05	flexspi.A_DQS	ALT 1	—
GPIO_SD_B1_11	flexspi.A_SS0_B	ALT 1	—
GPIO_SD_B0_00	flexspi.A_SS1_B	ALT 6	—
GPIO_SD_B1_07	flexspi.A_SCLK	ALT 1	—
GPIO_SD_B1_08	flexspi.A_DATA[0]	ALT 1	—
GPIO_SD_B1_10	flexspi.A_DATA[1]	ALT 1	—
GPIO_SD_B1_09	flexspi.A_DATA[2]	ALT 1	—
GPIO_SD_B1_06	flexspi.A_DATA[3]	ALT 1	—

Table 71. Boot through FlexSPI (second option)

PAD Name	IO Function	Mux Mode	Comments
GPIO_AD_B1_00	flexspi.A_DATA[3]	ALT 1	—
GPIO_AD_B1_01	flexspi.A_SCLK	ALT 1	—
GPIO_AD_B1_02	flexspi.A_DATA[0]	ALT 1	—
GPIO_AD_B1_03	flexspi.A_DATA[2]	ALT 1	—
GPIO_AD_B1_04	flexspi.A_DATA[1]	ALT 1	—
GPIO_AD_B1_05	flexspi.A_SS0_B	ALT 1	—

Table 72. FlexSPI reset

PAD Name	IO Function	Mux Mode	Comments
GPIO_AD_B1_13	gpio1.IO[29]	ALT 5	—

Table 73. Boot through SD1

PAD Name	IO Function	Mux Mode	Comments
GPIO_SD_B0_06	usdhc1.CD_B	ALT 0	—
GPIO_AD_B0_04	usdhc1.WP	ALT 2	—
GPIO_AD_B1_07	usdhc1.VSELECT	ALT 0	—
GPIO_AD_B1_06	usdhc1.RESET_B	ALT 0	—
GPIO_SD_B0_02	usdhc1.CMD	ALT 0	—
GPIO_SD_B0_03	usdhc1.CLK	ALT 0	—
GPIO_SD_B0_04	usdhc1.DATA0	ALT 0	—
GPIO_SD_B0_05	usdhc1.DATA1	ALT 0	—
GPIO_SD_B0_00	usdhc1.DATA2	ALT 0	—
GPIO_SD_B0_01	usdhc1.DATA3	ALT 0	—

Table 74. Boot through SD2

PAD Name	IO Function	Mux Mode	Comments
GPIO_SD_B1_06	usdhc2.CD_B	ALT 0	—
GPIO_AD_B1_13	usdhc2.WP	ALT 3	—
GPIO_SD_B1_07	usdhc2.RESET_B	ALT 0	—
GPIO_SD_B1_02	usdhc2.CMD	ALT 0	—
GPIO_SD_B1_03	usdhc2.CLK	ALT 0	—
GPIO_SD_B1_04	usdhc2.DATA0	ALT 0	—
GPIO_SD_B1_05	usdhc2.DATA1	ALT 0	—

Table 74. Boot through SD2 (continued)

PAD Name	IO Function	Mux Mode	Comments
GPIO_SD_B1_00	usdhc2.DATA2	ALT 0	—
GPIO_SD_B1_01	usdhc2.DATA3	ALT 0	—
GPIO_SD_B1_08	usdhc2.DATA4	ALT 0	—
GPIO_SD_B1_09	usdhc2.DATA5	ALT 0	—
GPIO_SD_B1_10	usdhc2.DATA6	ALT 0	—
GPIO_SD_B1_11	usdhc2.DATA7	ALT 0	—

Table 75. Boot through SPI-1

PAD Name	IO Function	Mux Mode	Comments
GPIO_AD_B0_10	lpspi1.SCK	ALT 1	—
GPIO_AD_B0_11	lpspi1.PCS0	ALT 1	—
GPIO_AD_B0_12	lpspi1.SDO	ALT 1	—
GPIO_AD_B0_13	lpspi1.SDI	ALT 1	—

Table 76. Boot through SPI-2

PAD Name	IO Function	Mux Mode	Comments
GPIO_SD_B1_07	lpspi2.SCK	ALT 4	—
GPIO_SD_B1_08	lpspi2.SDO	ALT 4	—
GPIO_SD_B1_09	lpspi2.SDI	ALT 4	—
GPIO_SD_B1_06	lpspi2.PCS0	ALT 4	—

Table 77. Boot through SPI-3

PAD Name	IO Function	Mux Mode	Comments
GPIO_AD_B1_12	lpspi3.SCK	ALT 2	—
GPIO_AD_B1_13	lpspi3.PCS0	ALT 2	—
GPIO_AD_B1_14	lpspi3.SDO	ALT 2	—
GPIO_AD_B1_15	lpspi3.SDI	ALT 2	—

Table 78. Boot through SPI-4

PAD Name	IO Function	Mux Mode	Comments
GPIO_EMC_32	lpspi4.SCK	ALT 4	—
GPIO_EMC_33	lpspi4.PCS0	ALT 4	—

Table 78. Boot through SPI-4 (continued)

PAD Name	IO Function	Mux Mode	Comments
GPIO_EMC_34	lpspi4.SDO	ALT 4	—
GPIO_EMC_35	lpspi4.SDI	ALT 4	—

Table 79. Boot through SEMC

PAD Name	IO Function	Mux Mode	Comments
GPIO_EMC_28	semc.DQS	ALT 0	—
GPIO_EMC_41	semc.RDY	ALT 0	—

Table 80. Boot through UART1

PAD Name	IO Function	Mux Mode	Comments
GPIO_AD_B0_06	lpuart1.TX	ALT 2	—
GPIO_AD_B0_07	lpuart1.RX	ALT 2	—
GPIO_AD_B0_08	lpuart1.CTS_B	ALT 2	—
GPIO_AD_B0_09	lpuart1.RTS_B	ALT 2	—

Table 81. Boot through UART2

PAD Name	IO Function	Mux Mode	Comments
GPIO_AD_B1_06	lpuart2.CTS_B	ALT 2	—
GPIO_AD_B1_07	lpuart2.RTS_B	ALT 2	—
GPIO_AD_B1_08	lpuart2.TX	ALT 2	—
GPIO_AD_B1_09	lpuart2.RX	ALT 2	—

6 Package information and contact assignments

This section includes the contact assignment information and mechanical package drawing.

6.1 20 x 20 mm package information

6.1.1 20 x 20 mm, 0.5 mm pitch, ball matrix

[Figure 49](#) shows the top, bottom, and side views of the 20 x 20 mm LQFP package.

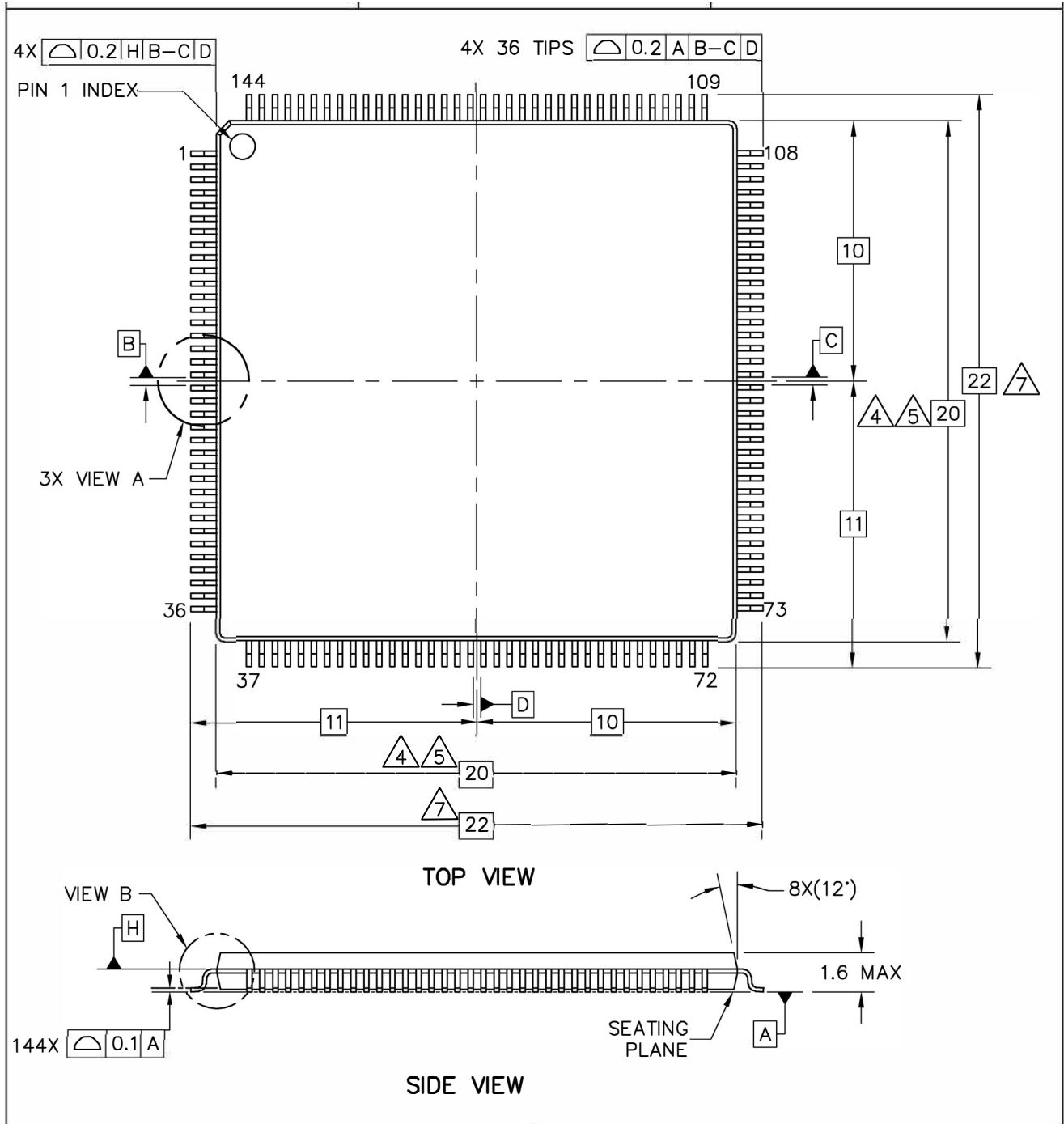

Figure 49. 20 x 20 mm LQFP, case x package top and side views

6.1.2 20 x 20 mm supplies contact assignments and functional contact assignments

Table 82 shows the device connection list for ground, sense, and reference contact signals.

Table 82. 20 x 20 mm supplies contact Assignment

Supply Rail Name	Pin(s) Position(s)	Remark
DCDC_IN	34	—
DCDC_IN_Q	38	—
DCDC_GND	35	—
DCDC_LP	36	—
DCDC_PSWITCH	37	—
GPANAIO	71	—
NGND_KEL0	64	—
NVCC_GPIO	11, 20, 29, 77, 104, 112, 144	—
NVCC_PLL	72	—
NVCC_SD0	44	—
VDDA_ADC_3P3	73	—
VDD_HIGH_CAP	65	—
VDD_HIGH_IN	69	—
VDD_SNVS_CAP	56	—
VDD_SNVS_IN	55	—
VDD_SOC_IN	5, 31, 39, 86, 102, 114, 134	—
VDD_USB_CAP	61	—
VSS	6, 40, 60, 70, 85, 103, 113, 135	—

Table 83 shows an alpha-sorted list of functional contact assignments for the 20 x 20 mm package.

Table 83. 20 x 20 mm functional contact assignments

Pin Name	20 x 20 Pin	Power Group	Pin Type	Default Setting			
				Default Mode	Default Function	Input/Output	Value
GPIO_AD_B0_00	111	NVCC_GPIO	Digital GPIO	ALT0	jtag_mux.TMS	Input	47 K PU
GPIO_AD_B0_01	110	NVCC_GPIO	Digital GPIO	ALT0	jtag_mux.TCK	Input	100 K PD
GPIO_AD_B0_02	109	NVCC_GPIO	Digital GPIO	ALT0	jtag_mux.MOD	Input	100 K PD

Table 83. 20 x 20 mm functional contact assignments (continued)

GPIO_AD_B0_03	108	NVCC_GPIO	Digital GPIO	ALT0	jtag_mux.TDI	Input	47 K PU
GPIO_AD_B0_04	107	NVCC_GPIO	Digital GPIO	ALT0	jtag_mux.TDO	Input	Keeper
GPIO_AD_B0_05	106	NVCC_GPIO	Digital GPIO	ALT0	jtag_mux.TRSTB	Input	47 K PU
GPIO_AD_B0_06	105	NVCC_GPIO	Digital GPIO	ALT5	GPIO1.IO[6]	Input	Keeper
GPIO_AD_B0_07	101	NVCC_GPIO	Digital GPIO	ALT5	GPIO1.IO[7]	Input	Keeper
GPIO_AD_B0_08	100	NVCC_GPIO	Digital GPIO	ALT5	GPIO1.IO[8]	Input	Keeper
GPIO_AD_B0_09	99	NVCC_GPIO	Digital GPIO	ALT5	GPIO1.IO[9]	Input	Keeper
GPIO_AD_B0_10	98	NVCC_GPIO	Digital GPIO	ALT5	GPIO1.IO[10]	Input	Keeper
GPIO_AD_B0_11	97	NVCC_GPIO	Digital GPIO	ALT5	GPIO1.IO[11]	Input	Keeper
GPIO_AD_B0_12	96	NVCC_GPIO	Digital GPIO	ALT5	GPIO1.IO[12]	Input	Keeper
GPIO_AD_B0_13	95	NVCC_GPIO	Digital GPIO	ALT5	GPIO1.IO[13]	Input	Keeper
GPIO_AD_B0_14	94	NVCC_GPIO	Digital GPIO	ALT5	GPIO1.IO[14]	Input	Keeper
GPIO_AD_B0_15	93	NVCC_GPIO	Digital GPIO	ALT5	GPIO1.IO[15]	Input	Keeper
GPIO_AD_B1_00	92	NVCC_GPIO	Digital GPIO	ALT5	GPIO1.IO[16]	Input	Keeper
GPIO_AD_B1_01	91	NVCC_GPIO	Digital GPIO	ALT5	GPIO1.IO[17]	Input	Keeper
GPIO_AD_B1_02	90	NVCC_GPIO	Digital GPIO	ALT5	GPIO1.IO[18]	Input	Keeper
GPIO_AD_B1_03	89	NVCC_GPIO	Digital GPIO	ALT5	GPIO1.IO[19]	Input	Keeper
GPIO_AD_B1_04	88	NVCC_GPIO	Digital GPIO	ALT5	GPIO1.IO[20]	Input	Keeper
GPIO_AD_B1_05	87	NVCC_GPIO	Digital GPIO	ALT5	GPIO1.IO[21]	Input	Keeper
GPIO_AD_B1_06	84	NVCC_GPIO	Digital GPIO	ALT5	GPIO1.IO[22]	Input	Keeper
GPIO_AD_B1_07	83	NVCC_GPIO	Digital GPIO	ALT5	GPIO1.IO[23]	Input	Keeper

Table 83. 20 x 20 mm functional contact assignments (continued)

GPIO_AD_B1_08	82	NVCC_GPIO	Digital GPIO	ALT5	GPIO1.IO[24]	Input	Keeper
GPIO_AD_B1_09	81	NVCC_GPIO	Digital GPIO	ALT5	GPIO1.IO[25]	Input	Keeper
GPIO_AD_B1_10	80	NVCC_GPIO	Digital GPIO	ALT5	GPIO1.IO[26]	Input	Keeper
GPIO_AD_B1_11	79	NVCC_GPIO	Digital GPIO	ALT5	GPIO1.IO[27]	Input	Keeper
GPIO_AD_B1_12	78	NVCC_GPIO	Digital GPIO	ALT5	GPIO1.IO[28]	Input	Keeper
GPIO_AD_B1_13	76	NVCC_GPIO	Digital GPIO	ALT5	GPIO1.IO[29]	Input	Keeper
GPIO_AD_B1_14	75	NVCC_GPIO	Digital GPIO	ALT5	GPIO1.IO[30]	Input	Keeper
GPIO_AD_B1_15	74	NVCC_GPIO	Digital GPIO	ALT5	GPIO1.IO[31]	Input	Keeper
GPIO_EMC_00	18	NVCC_GPIO	Digital GPIO	ALT5	GPIO2.IO[0]	Input	Keeper
GPIO_EMC_01	17	NVCC_GPIO	Digital GPIO	ALT5	GPIO2.IO[1]	Input	Keeper
GPIO_EMC_02	16	NVCC_GPIO	Digital GPIO	ALT5	GPIO2.IO[2]	Input	Keeper
GPIO_EMC_03	15	NVCC_GPIO	Digital GPIO	ALT5	GPIO2.IO[3]	Input	Keeper
GPIO_EMC_04	14	NVCC_GPIO	Digital GPIO	ALT5	GPIO2.IO[4]	Input	Keeper
GPIO_EMC_05	13	NVCC_GPIO	Digital GPIO	ALT5	GPIO2.IO[5]	Input	Keeper
GPIO_EMC_06	12	NVCC_GPIO	Digital GPIO	ALT5	GPIO2.IO[6]	Input	Keeper
GPIO_EMC_07	10	NVCC_GPIO	Digital GPIO	ALT5	GPIO2.IO[7]	Input	Keeper
GPIO_EMC_08	9	NVCC_GPIO	Digital GPIO	ALT5	GPIO2.IO[8]	Input	Keeper
GPIO_EMC_09	8	NVCC_GPIO	Digital GPIO	ALT5	GPIO2.IO[9]	Input	Keeper
GPIO_EMC_10	7	NVCC_GPIO	Digital GPIO	ALT5	GPIO2.IO[10]	Input	Keeper
GPIO_EMC_11	4	NVCC_GPIO	Digital GPIO	ALT5	GPIO2.IO[11]	Input	Keeper
GPIO_EMC_12	3	NVCC_GPIO	Digital GPIO	ALT5	GPIO2.IO[12]	Input	Keeper

Table 83. 20 x 20 mm functional contact assignments (continued)

GPIO_EMC_13	2	NVCC_GPIO	Digital GPIO	ALT5	GPIO2.IO[13]	Input	Keeper
GPIO_EMC_14	1	NVCC_GPIO	Digital GPIO	ALT5	GPIO2.IO[14]	Input	Keeper
GPIO_EMC_15	143	NVCC_GPIO	Digital GPIO	ALT5	GPIO2.IO[15]	Input	Keeper
GPIO_EMC_16	142	NVCC_GPIO	Digital GPIO	ALT6	SRC_BOOT_MODE0	Input	100K PD
GPIO_EMC_17	141	NVCC_GPIO	Digital GPIO	ALT6	SRC_BOOT_MODE1	Input	100K PD
GPIO_EMC_18	140	NVCC_GPIO	Digital GPIO	ALT5	GPIO2.IO[18]	Input	Keeper
GPIO_EMC_19	139	NVCC_GPIO	Digital GPIO	ALT5	GPIO2.IO[19]	Input	Keeper
GPIO_EMC_20	138	NVCC_GPIO	Digital GPIO	ALT5	GPIO2.IO[20]	Input	Keeper
GPIO_EMC_21	137	NVCC_GPIO	Digital GPIO	ALT5	GPIO2.IO[21]	Input	Keeper
GPIO_EMC_22	136	NVCC_GPIO	Digital GPIO	ALT5	GPIO2.IO[22]	Input	Keeper
GPIO_EMC_23	133	NVCC_GPIO	Digital GPIO	ALT5	GPIO2.IO[23]	Input	Keeper
GPIO_EMC_24	132	NVCC_GPIO	Digital GPIO	ALT5	GPIO2.IO[24]	Input	Keeper
GPIO_EMC_25	131	NVCC_GPIO	Digital GPIO	ALT5	GPIO2.IO[25]	Input	Keeper
GPIO_EMC_26	130	NVCC_GPIO	Digital GPIO	ALT5	GPIO2.IO[26]	Input	Keeper
GPIO_EMC_27	129	NVCC_GPIO	Digital GPIO	ALT5	GPIO2.IO[27]	Input	Keeper
GPIO_EMC_28	128	NVCC_GPIO	Digital GPIO	ALT5	GPIO2.IO[28]	Input	Keeper
GPIO_EMC_29	127	NVCC_GPIO	Digital GPIO	ALT5	GPIO2.IO[29]	Input	100k PD
GPIO_EMC_30	126	NVCC_GPIO	Digital GPIO	ALT5	GPIO2.IO[30]	Input	Keeper
GPIO_EMC_31	125	NVCC_GPIO	Digital GPIO	ALT5	GPIO2.IO[31]	Input	Keeper
GPIO_EMC_32	124	NVCC_GPIO	Digital GPIO	ALT5	GPIO3.IO[0]	Input	Keeper
GPIO_EMC_33	123	NVCC_GPIO	Digital GPIO	ALT5	GPIO3.IO[1]	Input	Keeper

Table 83. 20 x 20 mm functional contact assignments (continued)

GPIO_EMC_34	122	NVCC_GPIO	Digital GPIO	ALT5	GPIO3.IO[2]	Input	Keeper
GPIO_EMC_35	121	NVCC_GPIO	Digital GPIO	ALT5	GPIO3.IO[3]	Input	Keeper
GPIO_EMC_36	120	NVCC_GPIO	Digital GPIO	ALT5	GPIO3.IO[4]	Input	Keeper
GPIO_EMC_37	119	NVCC_GPIO	Digital GPIO	ALT5	GPIO3.IO[5]	Input	Keeper
GPIO_EMC_38	118	NVCC_GPIO	Digital GPIO	ALT5	GPIO3.IO[6]	Input	Keeper
GPIO_EMC_39	117	NVCC_GPIO	Digital GPIO	ALT5	GPIO3.IO[7]	Input	Keeper
GPIO_EMC_40	116	NVCC_GPIO	Digital GPIO	ALT5	GPIO3.IO[8]	Input	Keeper
GPIO_EMC_41	115	NVCC_GPIO	Digital GPIO	ALT5	GPIO3.IO[9]	Input	Keeper
GPIO_SD_B0_00	48	NVCC_SD0	Digital GPIO	ALT5	GPIO3.IO[13]	Input	Keeper
GPIO_SD_B0_01	47	NVCC_SD0	Digital GPIO	ALT5	GPIO3.IO[14]	Input	Keeper
GPIO_SD_B0_02	46	NVCC_SD0	Digital GPIO	ALT5	GPIO3.IO[15]	Input	Keeper
GPIO_SD_B0_03	45	NVCC_SD0	Digital GPIO	ALT5	GPIO3.IO[16]	Input	Keeper
GPIO_SD_B0_04	43	NVCC_SD0	Digital GPIO	ALT5	GPIO3.IO[17]	Input	Keeper
GPIO_SD_B0_05	42	NVCC_SD0	Digital GPIO	ALT5	GPIO3.IO[18]	Input	Keeper
GPIO_SD_B0_06	41	NVCC_SD0	Digital GPIO	ALT5	GPIO3.IO[19]	Input	Keeper
GPIO_SD_B1_00	33	NVCC_GPIO	Digital GPIO	ALT5	GPIO3.IO[20]	Input	Keeper
GPIO_SD_B1_01	32	NVCC_GPIO	Digital GPIO	ALT5	GPIO3.IO[21]	Input	Keeper
GPIO_SD_B1_02	30	NVCC_GPIO	Digital GPIO	ALT5	GPIO3.IO[22]	Input	Keeper
GPIO_SD_B1_03	28	NVCC_GPIO	Digital GPIO	ALT5	GPIO3.IO[23]	Input	Keeper
GPIO_SD_B1_04	27	NVCC_GPIO	Digital GPIO	ALT5	GPIO3.IO[24]	Input	Keeper
GPIO_SD_B1_05	26	NVCC_GPIO	Digital GPIO	ALT5	GPIO3.IO[25]	Input	Keeper

Table 83. 20 x 20 mm functional contact assignments (continued)

GPIO_SD_B1_06	25	NVCC_GPIO	Digital GPIO	ALT5	GPIO3.IO[26]	Input	Keeper
GPIO_SD_B1_07	24	NVCC_GPIO	Digital GPIO	ALT5	GPIO3.IO[27]	Input	Keeper
GPIO_SD_B1_08	23	NVCC_GPIO	Digital GPIO	ALT5	GPIO3.IO[28]	Input	Keeper
GPIO_SD_B1_09	22	NVCC_GPIO	Digital GPIO	ALT5	GPIO3.IO[29]	Input	Keeper
GPIO_SD_B1_10	21	NVCC_GPIO	Digital GPIO	ALT5	GPIO3.IO[30]	Input	Keeper
GPIO_SD_B1_11	19	NVCC_GPIO	Digital GPIO	ALT5	GPIO3.IO[31]	Input	Keeper
ONOFF	49	VDD_SNVS_IN	Digital GPIO	ALT0	src.RESET_B	Input	100 K PU
PMIC_ON_REQ	53	VDD_SNVS_IN	Digital GPIO	ALT0	snvs_lp.PMIC_ON_REQ	Input	100 K PU
PMIC_STBY_REQ	54	VDD_SNVS_IN	Digital GPIO	ALT0	ccm.PMIC_VSTBY_REQ	Output	100 K PU (PKE disabled)
POR_B	50	VDD_SNVS_IN	Digital GPIO	ALT0	src.POR_B	Input	100 K PU
RTC_XTALI	57	—	—	—	—	—	—
RTC_XTALO	58	—	—	—	—	—	—
TEST_MODE	51	VDD_SNVS_IN	Digital GPIO	ALT0	tcu.TEST_MODE	Input	100 K PD
USB_OTG1_CHD_B	66	—	—	—	—	—	—
USB_OTG1_DN	62	—	—	—	—	—	—
USB_OTG1_DP	63	—	—	—	—	—	—
USB_OTG1_VBUS	59	—	—	—	—	—	—
XTALI	67	—	—	—	—	—	—
XTALO	68	—	—	—	—	—	—
WAKEUP	52	VDD_SNVS_IN	Digital GPIO	ALT5	GPIO5.IO[0]	Input	100 K PU

6.1.3 20 x 20 mm package pin assignments

Figure 50 shows the pin assignments of the 20 x 20 mm package.

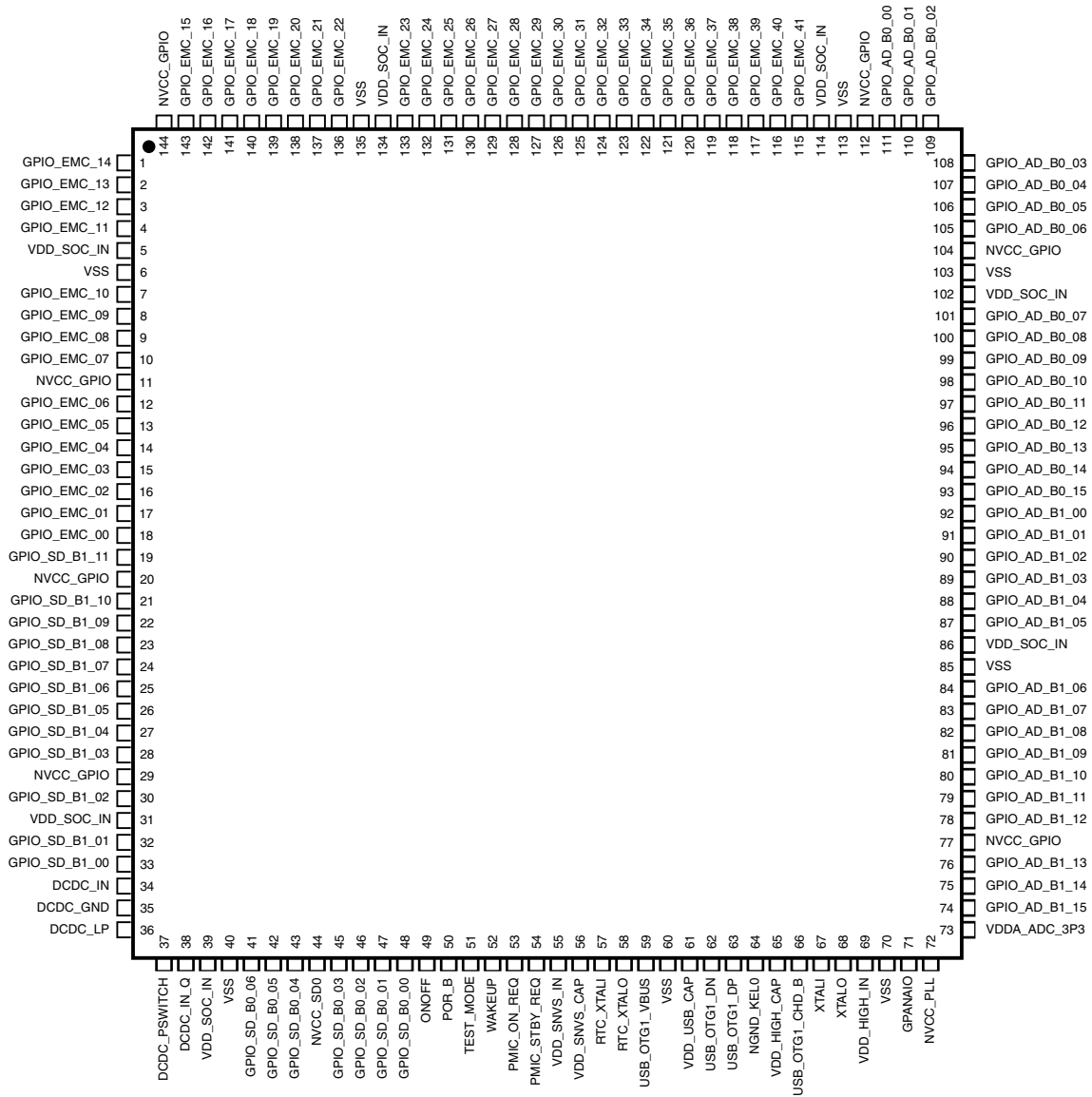

Figure 50. The pin assignments of the 20 x 20 mm package

6.2 14 x 14 mm package information

6.2.1 14 x 14 mm, 0.5 mm pitch, ball matrix

Figure 51 shows the top and side views of the 14 x 14 mm LQFP package.

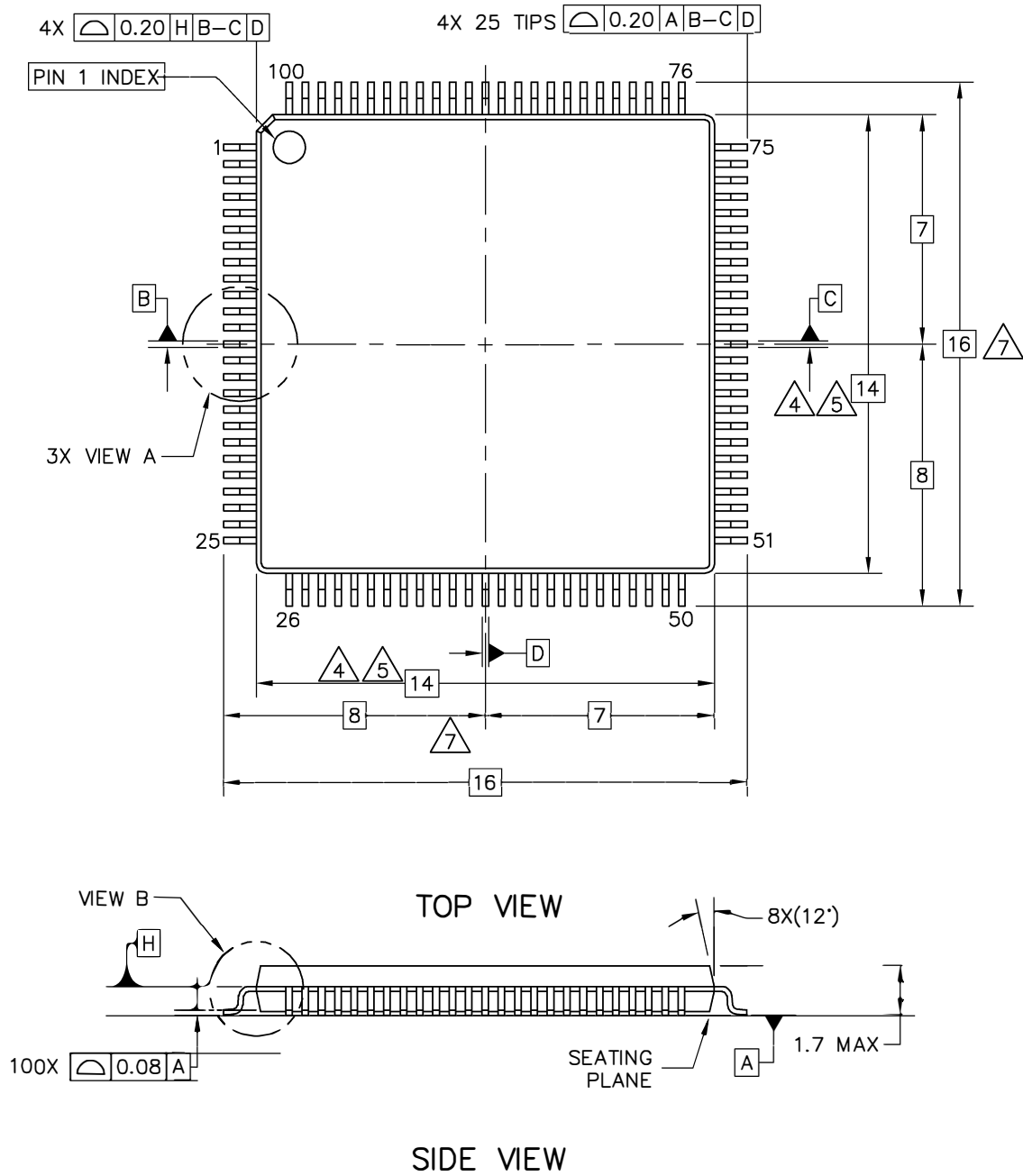

Figure 51. 14 x 14 mm LQFP, case x package top and side Views

6.2.2 14 x 14 mm supplies contact assignments and functional contact assignments

Table 84 shows the device connection list for ground, sense, and reference contact signals.

Table 84. 14 x 14 mm supplies contact assignment

Supply Rail Name	Pin(s) Position(s)	Remark
DCDC_IN	23	—
DCDC_IN_Q	27	—
DCDC_GND	24	—
DCDC_LP	25	—
DCDC_PSWITCH	26	—
NVCC_GPIO	5, 20, 58, 71, 80, 95	—
NGND_KEL0	43	—
NVCC_PLL	50	—
VDD_HIGH_CAP	44	—
VDD_HIGH_IN	48	—
VDD_SNVS_CAP	35	—
VDD_SNVS_IN	34	—
VDD_SOC_IN	18, 28, 69, 81, 91	—
VDD_USB_CAP	40	—
VDDA_ADC_3P3	51	—
VSS	19, 29, 39, 49, 59, 70, 79, 92	—

Table 85 shows an alpha-sorted list of functional contact assignments for the 14 x 14 mm package.

Table 85. 14 x 14 mm functional contact assignments

Pin Name	14 x 14 Pin	Power Group	Pin Type	Default Setting			
				Default Mode	Default Function	Input/Output	Value
GPIO_AD_B0_00	78	NVCC_GPIO	Digital GPIO	ALT0	jtag_mux.TMS	Input	47 K PU
GPIO_AD_B0_01	77	NVCC_GPIO	Digital GPIO	ALT0	jtag_mux.TCK	Input	100 K PD
GPIO_AD_B0_02	76	NVCC_GPIO	Digital GPIO	ALT0	jtag_mux.MOD	Input	100 K PD
GPIO_AD_B0_03	75	NVCC_GPIO	Digital GPIO	ALT0	jtag_mux.TDI	Input	47 K PU
GPIO_AD_B0_04	74	NVCC_GPIO	Digital GPIO	ALT0	jtag_mux.TDO	Input	Keeper

Table 85. 14 x 14 mm functional contact assignments (continued)

GPIO_AD_B0_05	73	NVCC_GPIO	Digital GPIO	ALT0	jtag_mux.TRSTB	Input	47 K PU
GPIO_AD_B0_06	72	NVCC_GPIO	Digital GPIO	ALT5	GPIO1.IO[6]	Input	Keeper
GPIO_AD_B0_07	68	NVCC_GPIO	Digital GPIO	ALT5	GPIO1.IO[7]	Input	Keeper
GPIO_AD_B0_08	67	NVCC_GPIO	Digital GPIO	ALT5	GPIO1.IO[8]	Input	Keeper
GPIO_AD_B0_09	66	NVCC_GPIO	Digital GPIO	ALT5	GPIO1.IO[9]	Input	Keeper
GPIO_AD_B0_10	65	NVCC_GPIO	Digital GPIO	ALT5	GPIO1.IO[10]	Input	Keeper
GPIO_AD_B0_11	64	NVCC_GPIO	Digital GPIO	ALT5	GPIO1.IO[11]	Input	Keeper
GPIO_AD_B0_12	63	NVCC_GPIO	Digital GPIO	ALT5	GPIO1.IO[12]	Input	Keeper
GPIO_AD_B0_13	62	NVCC_GPIO	Digital GPIO	ALT5	GPIO1.IO[13]	Input	Keeper
GPIO_AD_B0_14	61	NVCC_GPIO	Digital GPIO	ALT5	GPIO1.IO[14]	Input	Keeper
GPIO_AD_B0_15	60	NVCC_GPIO	Digital GPIO	ALT5	GPIO1.IO[15]	Input	Keeper
GPIO_AD_B1_10	57	NVCC_GPIO	Digital GPIO	ALT5	GPIO1.IO[26]	Input	Keeper
GPIO_AD_B1_11	56	NVCC_GPIO	Digital GPIO	ALT5	GPIO1.IO[27]	Input	Keeper
GPIO_AD_B1_12	55	NVCC_GPIO	Digital GPIO	ALT5	GPIO1.IO[28]	Input	Keeper
GPIO_AD_B1_13	54	NVCC_GPIO	Digital GPIO	ALT5	GPIO1.IO[29]	Input	Keeper
GPIO_AD_B1_14	53	NVCC_GPIO	Digital GPIO	ALT5	GPIO1.IO[30]	Input	Keeper
GPIO_AD_B1_15	52	NVCC_GPIO	Digital GPIO	ALT5	GPIO1.IO[31]	Input	Keeper
GPIO_EMC_04	7	NVCC_GPIO	Digital GPIO	ALT5	GPIO2.IO[4]	Input	Keeper
GPIO_EMC_05	6	NVCC_GPIO	Digital GPIO	ALT5	GPIO2.IO[5]	Input	Keeper
GPIO_EMC_06	4	NVCC_GPIO	Digital GPIO	ALT5	GPIO2.IO[6]	Input	Keeper
GPIO_EMC_07	3	NVCC_GPIO	Digital GPIO	ALT5	GPIO2.IO[7]	Input	Keeper

Table 85. 14 x 14 mm functional contact assignments (continued)

GPIO_EMC_08	2	NVCC_GPIO	Digital GPIO	ALT5	GPIO2.IO[8]	Input	Keeper
GPIO_EMC_09	1	NVCC_GPIO	Digital GPIO	ALT5	GPIO2.IO[9]	Input	Keeper
GPIO_EMC_16	100	NVCC_GPIO	Digital GPIO	ALT6	src.BOOT_MODE[0]	Input	100 k PD
GPIO_EMC_17	99	NVCC_GPIO	Digital GPIO	ALT6	src.BOOT_MODE[1]	Input	100 k PD
GPIO_EMC_18	98	NVCC_GPIO	Digital GPIO	ALT5	GPIO2.IO[18]	Input	Keeper
GPIO_EMC_19	97	NVCC_GPIO	Digital GPIO	ALT5	GPIO2.IO[19]	Input	Keeper
GPIO_EMC_20	96	NVCC_GPIO	Digital GPIO	ALT5	GPIO2.IO[20]	Input	Keeper
GPIO_EMC_21	94	NVCC_GPIO	Digital GPIO	ALT5	GPIO2.IO[21]	Input	Keeper
GPIO_EMC_22	93	NVCC_GPIO	Digital GPIO	ALT5	GPIO2.IO[22]	Input	Keeper
GPIO_EMC_23	90	NVCC_GPIO	Digital GPIO	ALT5	GPIO2.IO[23]	Input	Keeper
GPIO_EMC_24	89	NVCC_GPIO	Digital GPIO	ALT5	GPIO2.IO[24]	Input	Keeper
GPIO_EMC_25	88	NVCC_GPIO	Digital GPIO	ALT5	GPIO2.IO[25]	Input	Keeper
GPIO_EMC_26	87	NVCC_GPIO	Digital GPIO	ALT5	GPIO2.IO[26]	Input	Keeper
GPIO_EMC_27	86	NVCC_GPIO	Digital GPIO	ALT5	GPIO2.IO[27]	Input	Keeper
GPIO_EMC_32	85	NVCC_GPIO	Digital GPIO	ALT5	GPIO3.IO[0]	Input	Keeper
GPIO_EMC_33	84	NVCC_GPIO	Digital GPIO	ALT5	GPIO3.IO[1]	Input	Keeper
GPIO_EMC_34	83	NVCC_GPIO	Digital GPIO	ALT5	GPIO3.IO[2]	Input	Keeper
GPIO_EMC_35	82	NVCC_GPIO	Digital GPIO	ALT5	GPIO3.IO[3]	Input	Keeper
GPIO_SD_B1_00	22	NVCC_GPIO	Digital GPIO	ALT5	GPIO3.IO[20]	Input	Keeper
GPIO_SD_B1_01	21	NVCC_GPIO	Digital GPIO	ALT5	GPIO3.IO[21]	Input	Keeper
GPIO_SD_B1_02	17	NVCC_GPIO	Digital GPIO	ALT5	GPIO3.IO[22]	Input	Keeper

Table 85. 14 x 14 mm functional contact assignments (continued)

GPIO_SD_B1_03	16	NVCC_GPIO	Digital GPIO	ALT5	GPIO3.IO[23]	Input	Keeper
GPIO_SD_B1_04	15	NVCC_GPIO	Digital GPIO	ALT5	GPIO3.IO[24]	Input	Keeper
GPIO_SD_B1_05	14	NVCC_GPIO	Digital GPIO	ALT5	GPIO3.IO[25]	Input	Keeper
GPIO_SD_B1_06	13	NVCC_GPIO	Digital GPIO	ALT5	GPIO3.IO[26]	Input	Keeper
GPIO_SD_B1_07	12	NVCC_GPIO	Digital GPIO	ALT5	GPIO3.IO[27]	Input	Keeper
GPIO_SD_B1_08	11	NVCC_GPIO	Digital GPIO	ALT5	GPIO3.IO[28]	Input	Keeper
GPIO_SD_B1_09	10	NVCC_GPIO	Digital GPIO	ALT5	GPIO3.IO[29]	Input	Keeper
GPIO_SD_B1_10	9	NVCC_GPIO	Digital GPIO	ALT5	GPIO3.IO[30]	Input	Keeper
GPIO_SD_B1_11	8	NVCC_GPIO	Digital GPIO	ALT5	GPIO3.IO[31]	Input	Keeper
ONOFF	30	VDD_SNVS_IN	Digital GPIO	ALT0	src.RESET_B	Input	100 K PU
PMIC_ON_REQ	33	VDD_SNVS_IN	Digital GPIO	ALT0	snvs_lp.PMIC_ON_REQ	Input	100 K PU
POR_B	31	VDD_SNVS_IN	Digital GPIO	ALT0	src.POR_B	Output	100 K PU
RTC_XTALI	36	—	—	—	—	—	—
RTC_XTALO	37	—	—	—	—	—	—
TEST_MODE	32	VDD_SNVS_IN	Digital GPIO	ALT0	tcu.TEST_MODE	Input	100 K PD
USB_OTG1_CHD_B	45	—	—	—	—	—	—
USB_OTG1_DN	41	—	—	—	—	—	—
USB_OTG1_DP	42	—	—	—	—	—	—
USB_OTG1_VBUS	38	—	—	—	—	—	—
XTALI	46	—	—	—	—	—	—
XTALO	47	—	—	—	—	—	—

6.2.3 14 x 14 mm package pin assignments

Figure 52 shows the pin assignments of the 14 x 14 mm package.

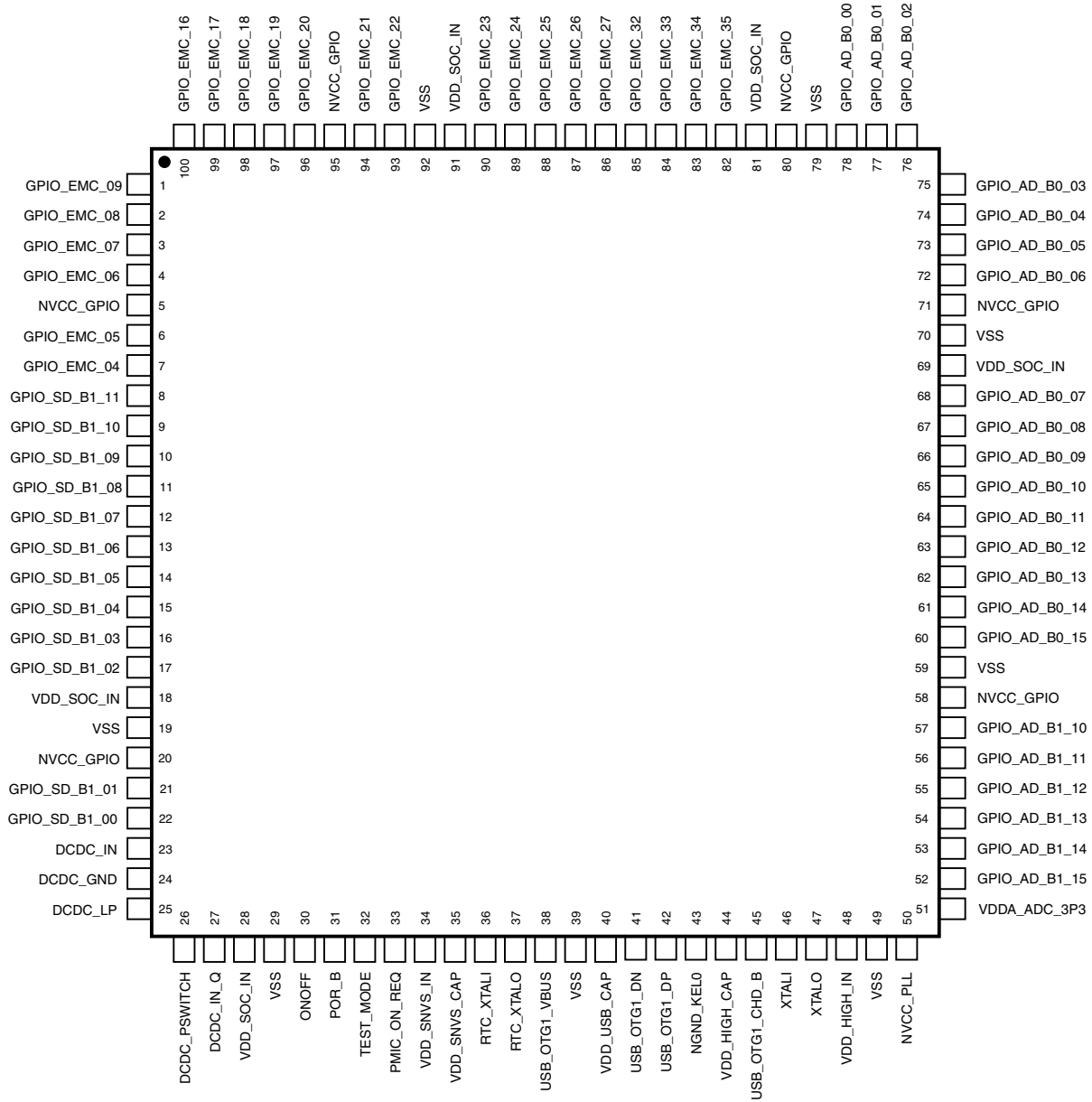

Figure 52. The pin assignments of the 14 x 14 mm package

7 Revision history

Table 86 provides a revision history for this data sheet.

Table 86. i.MX RT1020 data sheet document revision history

Rev. Number	Date	Substantive Change(s)
Rev. 1	04/2019	<ul style="list-style-type: none"> • Added analog descriptions in the Section 1.1, Features • Added ADC channel number in the Table 1, The comparison between 100 LQFP and 144 LQFP package • Updated the RT website link in the Section 1.2, Ordering information • Updated the ADC descriptions in the Figure 2, "i.MX RT1020 system block diagram" • Updated the RAM size, SNVS descriptions, and USB descriptions in the Table 3, i.MX RT1020 modules list • Updated the on-chip termination values of JTAG_TCK and JTAG_MOD in the Table 5, JTAG controller interface summary • Updated the maximum values of VDD_SOC_IN in the Table 8, Absolute maximum ratings • Removed the USB_OTG2_VBUS from the Table 8, Absolute maximum ratings, Table 11, Operating ranges, and Section 4.2.1.1, Power-up sequence • Changed 528 MHz PLL to System PLL in the Table 17, System PLL's electrical parameters • Changed 480 MHz PLL to USB PLL in the Table 19, USB PLL's electrical parameters • Updated the Section 4.8.1, LPSPi timing parameters • Added the Figure 32, "Minimum Sample Time Vs Ras (Cas = 2pF)", Figure 33, "Minimum Sample Time Vs Ras (Cas = 5 pF)", and Figure 34, "Minimum Sample Time Vs Ras (Cas = 10 pF)" in the Section 4.7.2, A/D converter
Rev. 0.1	07/2018	<ul style="list-style-type: none"> • Updated the Table 14, Low power mode current and power consumption • Added the Section 4.4.4, Debug trace timing specifications
Rev. 0	06/2018	<ul style="list-style-type: none"> • Initial version



How to Reach Us:

Home Page:
nxp.com

Web Support:
nxp.com/support

Information in this document is provided solely to enable system and software implementers to use NXP products. There are no express or implied copyright licenses granted hereunder to design or fabricate any integrated circuits based on the information in this document. NXP reserves the right to make changes without further notice to any products herein.

NXP makes no warranty, representation, or guarantee regarding the suitability of its products for any particular purpose, nor does NXP assume any liability arising out of the application or use of any product or circuit, and specifically disclaims any and all liability, including without limitation consequential or incidental damages. "Typical" parameters that may be provided in NXP data sheets and/or specifications can and do vary in different applications, and actual performance may vary over time. All operating parameters, including "typicals" must be validated for each customer application by customer, customer's technical experts. NXP does not convey any license under its patent rights nor the rights of others. NXP sells products pursuant to standard terms and conditions of sale, which can be found at the following address: nxp.com/SalesTermsandConditions.

While NXP has implemented advanced security features, all products may be subject to unidentified vulnerabilities. Customers are responsible for the design and operation of their applications and products to reduce the effect of these vulnerabilities on customer's applications and products, and NXP accepts no liability for any vulnerability that is discovered. Customers should implement appropriate design and operating safeguards to minimize the risks associated with their applications and products.

NXP, the NXP logo, NXP SECURE CONNECTIONS FOR A SMARTER WORLD, COOLFLUX, EMBRACE, GREENCHIP, HITAG, I2C BUS, ICODE, JCOP, LIFE VIBES, MIFARE, MIFARE CLASSIC, MIFARE DESFire, MIFARE PLUS, MIFARE FLEX, MANTIS, MIFARE ULTRALIGHT, MIFARE4MOBILE, MIGLO, NTAG, ROADLINK, SMARTLX, SMARTMX, STARPLUG, TOPFET, TRENCHMOS, UCODE, Freescale, the Freescale logo, Altivec, C-5, CodeTEST, CodeWarrior, ColdFire, ColdFire+, C-Ware, the Energy Efficient Solutions logo, Kinetic, Layerscape, MagniV, mobileGT, PEG, PowerQUICC, Processor Expert, QorIQ, QorIQ Qonverge, Ready Play, SafeAssure, the SafeAssure logo, StarCore, Symphony, VortiQa, Vybrid, Airfast, BeeKit, BeeStack, CoreNet, Flexis, MXC, Platform in a Package, QUICC Engine, SMARTMOS, Tower, TurboLink, and UMEMS, EdgeScale, EdgeLock, eIQ, and Immersive 3D are trademarks of NXP B.V. All other product or service names are the property of their respective owners. These are contained within the 6 series RMs Arm, AMBA, Arm Powered, Cortex, Jazelle, Thumb, and TrustZone are registered trademarks of Arm Limited (or its subsidiaries) in the EU and/or elsewhere. CoreLink, CoreSight, and NEON are trademarks of Arm Limited (or its subsidiaries) in the EU and/or elsewhere. All rights reserved. Oracle and Java are registered trademarks of Oracle and/or its affiliates. The Power Architecture and Power.org word marks and the Power and Power.org logos and related marks are trademarks and service marks licensed by Power.org.

© 2018-2019 NXP B.V.

Document Number: IMXRT1020IEC
Rev. 1
04/2019



Mouser Electronics

Authorized Distributor

Click to View Pricing, Inventory, Delivery & Lifecycle Information:

NXP:

[MIMXRT1021CAF4A](#) [MIMXRT1021CAG4A](#)