

XGZP Pressure Sensor(DIP6)

Features

- Ranges: -100~7kPaG...1000kPaG(-15~1PSI...150PSIG)
- MEMS Technology,Solid-state reliability
- Low cost for high volume application
- Dual-In-Line(DIP 6 Pins)
- For non-corrosive gas or air
- Working temp.: -30°C~+100°C(-22°F~+212°F)
- Gauge pressure type
- Easy to use and embed in OEM equipment

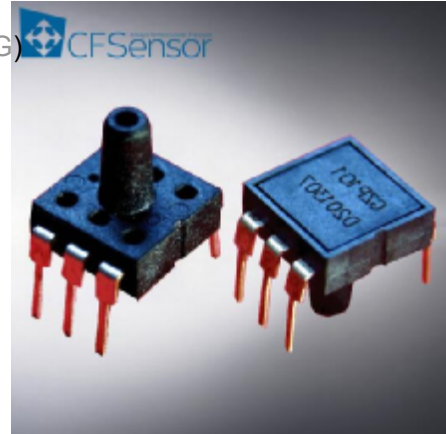

Application

- For Medical field, such as digital bleeding pressure meter, breathing machine, oxygen generating equipment, monitor etc, medical instruments and device.
- For Consumer&Automotive electronics field, such as tire pressure gauge, MAP sensor etc.
- For Other fields, such as environment monitoring, liquid level measurement, sport and fitness equipment, air bed, meteorology, other pneumatic device etc.

Introduction

XGZP is a surface mounting pressure sensor based on CFSensor silicon based piezoresistive pressure sensor die(XGZP2009).The sensor die is bonded on a substrate with a plastic cap and packaged in a 6-pin DIP.The small size and high reliability of on-chip integration make this sensor a simple and economical choice for high volume application in a variety of industries.

With standard DIP6 package, XGZP is easy for users to install through hole board assembly.

With good repeatability, linearity, stability and sensibility, XGZP is very facile for users to calibrate output & thermal drift and make temperature compensation by using exterior operational amplifier or integrated circuit.

The XGZP DIP6 pressure sensor is intended for use with non-corrosive gas or air. It is highly prohibited to choke the side of pressure diaphragm during actual application.Please consult us if a pressure medium other than air is to be used.

For direct application if required, please check XGZP6847 or consult factory.

Electronic Performance

- Power Supply: $\leq 10\text{Vdc}$ or $\leq 3.0\text{mAdc}$
- Input Impedance : $4\text{k}\Omega \sim 6\text{k}\Omega$
- Output Impedance : $4\text{k}\Omega \sim 6\text{k}\Omega$
- Insulation Resistor: $100\text{M}\Omega, 100\text{VDC}$
- Over Pressure:
 - $100 \sim 10\text{kPa} \dots 200\text{kPa}$ ($0 \sim 1\text{PSI} \dots 30\text{PSI}$): 2X Rated Pressure
 - $100 \sim 500\text{kPa} \dots 1000\text{kPa}$ ($0 \sim 75\text{PSI} \dots 150\text{PSI}$): 1.5X Rated Pressure

Construction

- Sensing Die: Silicon(XGZP2009)
- Die Mounting Glue: Silicone Glue ($\leq 200\text{kPa}/30\text{PSI}$) or Epoxy Glue ($> 200\text{kPa}/30\text{PSI}$)
- Leading wire: Gold Wire
- Package Housing: PPS(Phenylene sulfide)
- Pin: Silver Plated Copper
- Net Weight: Approx.1g

Environment Condition

- Orientation: Deviate 90° from any direction, zero change $\leq 0.05\%FS$
- Shock: No change at 10gRMS , ($20 \sim 2000$)Hz condition
- Impact: $100\text{g}, 11\text{ms}$
- Medium Compatibility:
 - Pressure side: air or gas compatible with silicone, silicone glue, epoxy glue or PPS
 - Reference side: dry air and non-corrosive gas compatible with PPS, silicon and silicone glue or epoxy, aluminum and silver.

Test Condition

- Medium: Gas(Clean, air and Non-corrosive gases)
- Medium Temp: $(25 \pm 1)^\circ\text{C}/(77 \pm 1.8)^\circ\text{F}$
- Environment Temp.: $(25 \pm 1)^\circ\text{C}/(77 \pm 1.8)^\circ\text{F}$
- Shock: 0.1g (1m/s^2) Max
- Humidity: $(50\% \pm 10\%)$ RH
- Power Supply: (5 ± 0.005) VDC

Specifications

Specifications		Min.	Typ.	Max	Unit
Pressure Range①		-100,7,10,20,40,100,200,500,700,1000			kPa
		-15,1,1.5,2.9,5.8,15,30,105,150			PSI
		-750,53,75,150,300,750,1500,3750...			mmHg
Ambient Temperature		-30/-22		+100/212	°C/°F
Storage Temperature		-40/-40		+125/257	°C/°F
Bridge Resistance		4	5	6	kΩ
Offset/Zero Output		-5		+10	mV
FS Output	≤10kPa/1.45PSI	20	35	50	mV
	20kPa/2.9PSI	30	45	60	mV
	40kPa/5.8PSI	50	70	90	mV
	≥100kPa/≥15PSI	60	90	150	mV
Temp. Coefficient of Resistance		2000	2500	3000	ppm/°C
TCO(Temp. Coefficient of Offset)		-0.2②		0.2②	%FS/°C
		-0.06③		0.06③	%FS/°C
TCS(Temp. Coefficient of Span)④		-0.25②	-0.21②	-0.17②	%FS/°C
		-0.06③		0.06③	%FS/°C
Linearity⑤		-0.3		0.3	%FS
Hysteresis		-0.2		0.2	%FS
Repeatability		-0.2		0.2	%FS
Long-term Stability		-1.0		1.0	%FS
Response Time			2		mSec.

Note:

- ①The max negative pressure specified above is exactly 98.07kPa in actual application.
 - ②Excited by constant voltage
 - ③Excited by constant current
 - ④Defined as best fit straight line
 - ⑤Temperature coefficient is measured from 0°C to 80°C.(32°F~176°F)
- Unless otherwise specified,measurements were taken on base of above testing condition.

Reference Data
(Base)

on above test condition)

Linearity

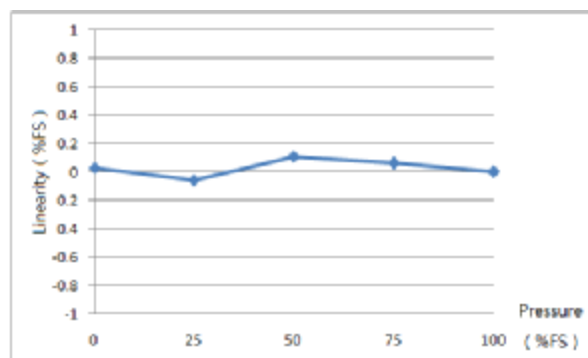

TCO-Constant Current

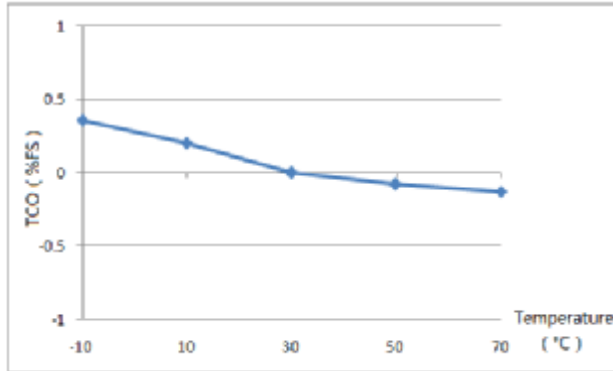

TCS-Constant Current

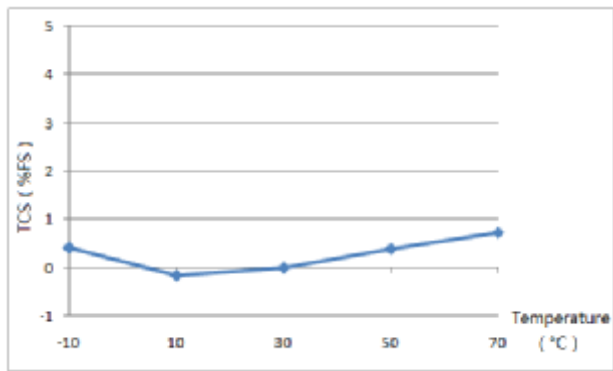

TCO-Constant Voltage

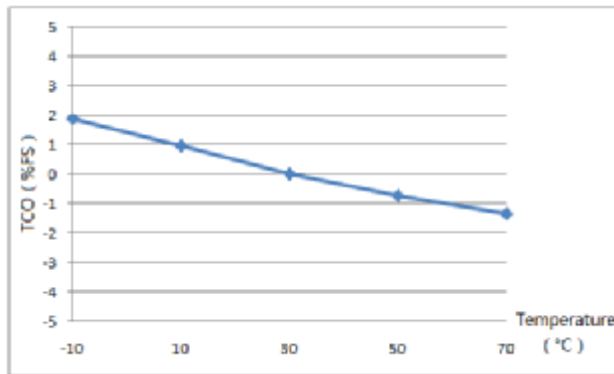

TCS-Constant Voltage

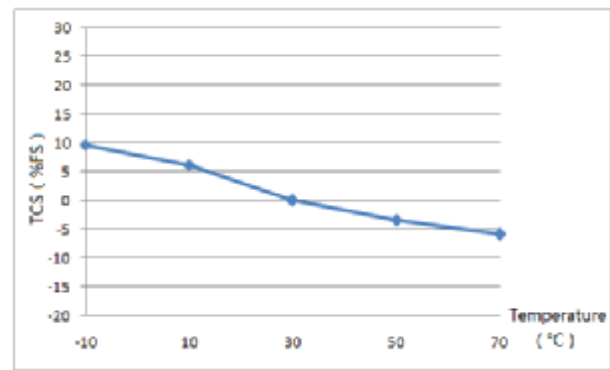
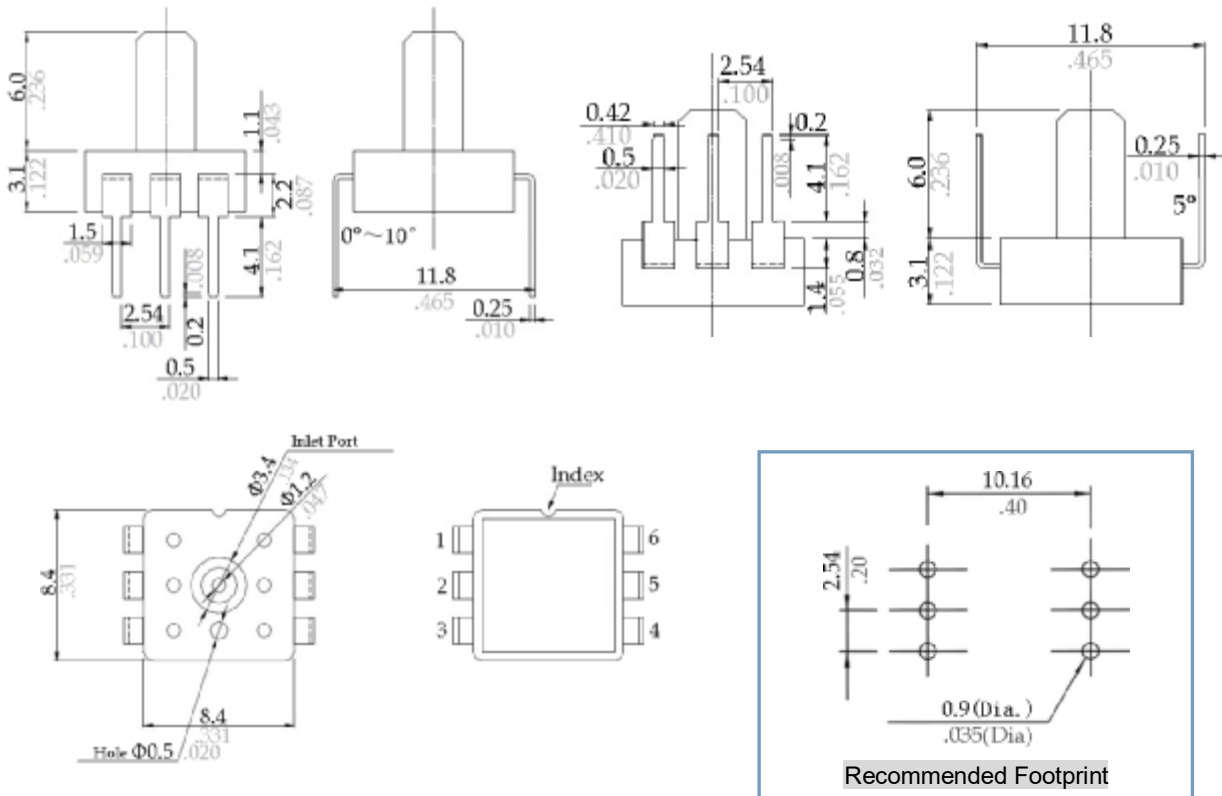
Dimension (Unit:mm/Inch)

PIN Connection & Definition

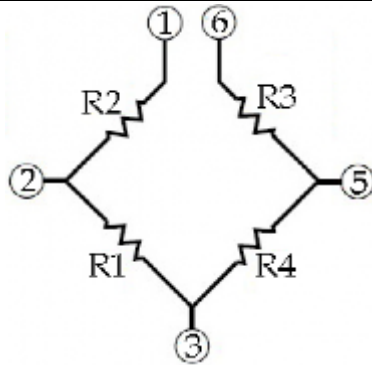

Pin	1	2	3	4	5	6
Definition B1	Vo-	Vs+	Vo+	N/C	GND	Vo-
Definition B2	GND	Vo+	Vs+	N/C	Vo-	GND

Symbol	Vs+	GND	Vo+	Vo-
Definition	Power +	Power -	Output +	Output -

☀ B1 as default PIN Definition unless otherwise specified.

Order Guide

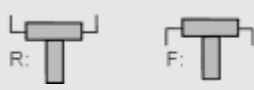
XGZP	Piezo-resistive Pressure Sensor			
	Code	Range	100kPa=0.1mKp=750mmHg=10MH2O≈1bar≈14.5PSI	
	007G	0~7kPa	Available for Negative pressure(-7~7kPa)	
	010G	0~10kPa	Available for Negative pressure(-10~10kPa)	
	020G	0~20kPa	Available for Negative pressure(-40~20kPa)	
	040G	0~40kPa	Available for Negative pressure(-40~40kPa)	
	101G	0~100kPa	Available for Negative pressure(-100~100kPa)	
	201G	0~200kPa	Available for Negative pressure(-100~200kPa)	
	501G	0~500kPa	Available for Negative pressure(-100~500kPa)	
	701G	0~700kPa	Available for Negative pressure(-100~700kPa)	
	102G	0~1000kPa	Available for Negative pressure(-100~700kPa)	
	Code	Package Type		
	D	DIP		
		Code	PIN	
		B1	PIN Def.1	
		B2	PIN Def.2	
		Code		
		R		
		F		
XGZP	101G	D	B1	the whole spec.

Notes:

■ Mounting

Adopting land on the PC board for ensuring the sensor is securely fixed.

■ Soldering

Due to its small size, the thermal capacity of the pressure sensor is low. Therefore, take steps to minimize the effects of external heat.

Damage and changes to characteristics may occur due to heat deformation.

Use a non-corrosive resin type of flux.

Since the pressure sensor is exposed to the atmosphere, do not allow flux to enter inside.

▼ Manual soldering

Set the soldering tip from 260 to 300°C (30W), and solder for no more than 5 seconds.

Please note that output may change if the pressure is applied on the terminals when the soldering.

Thoroughly clean the soldering iron.

▼ SMD soldering

Please keep the SMD solder bath temperature no higher than 260°C/500°F. When soldering, heat should be applied no longer than five seconds.

When mounting onto a PCB of low thermal capacity, please avoid SMD soldering as this may cause heat deformity.

▼ Solder reworking

Finish reworking in one operation.

For reworking of the solder bridge, use a soldering iron with a flat tip. Please do not add more flux when reworking.

Please use a soldering iron that is below the temperature given in the specifications in order to maintain the correct temperature at the tip of the soldering iron.

Too much force on the terminals will cause deformation and loss in effectiveness of the solder. Therefore, please avoid dropping and careless handling of the product.

Please control warping of the PCB within 0.05 mm of the sensor width.

When cut folding the PCB after mounting the sensor, take measures to prevent stress to the soldered parts.

The sensor terminals are designed to be exposed, so contact of the terminals with metal shards and the like will cause output errors. Therefore, please be careful and prevent things such as metal shards and hands from contacting the terminals.

To prevent degradation of the PCB insulation after soldering, please be careful not to get chemicals on the sensor when coating.

Please consult us regarding the use of lead-free solder.

■ Cleaning

▼ Since the pressure sensor chip is exposed to the atmosphere, do not allow cleaning fluid to enter inside.

▼ Avoid ultrasonic cleaning since this may cause breaks or disconnections in the wiring.

■ Environment

▼ Please avoid using or storing the pressure sensor chip in a place exposed to corrosive gases (such as the gases given off by organic solvents, sulfurous acid gas, hydrogen sulfides, etc.) which will adversely affect the performance of the pressure sensor chip.

▼ Since this pressure sensor chip does not have a water-proof construction, please do not use the sensor in a location where it may be sprayed with water, etc.

▼ Avoid using the pressure sensors chip in an environment where condensation may form. Furthermore, its output may fluctuate if any moisture adhering to it freezes.

▼ The pressure sensor chip is constructed in such a way that its output will fluctuate when it is exposed to light. Especially when pressure is to be applied by means of a transparent tube, take steps to prevent the pressure sensor chip from being exposed to light.

▼ Avoid using the pressure sensor chip where it will be susceptible to ultrasonic or other high-frequency vibration.

■ Quality check under actual loading conditions

To assure reliability, check the sensor under actual loading conditions. Avoid any situation that may adversely affect its performance.

■ Other handling precautions

▼ That using the wrong pressure range or mounting method may result in accidents.

▼ The only direct pressure medium you can use is dry air. The use of other media, in particular, corrosive gases (organic solvent based gases, sulfurous acid based gases, and hydrogen sulfide

based gases, etc.) and media that contains moisture or foreign substances will cause malfunction and damage. Please do not use them.

▼ The pressure sensor chip is positioned inside the pressure inlet. Never poke wires or other foreign matter through the pressure inlet since they may damage the chip or block the inlet. Avoid use when the atmospheric pressure inlet is blocked.

▼ Use an operating pressure which is within the rated pressure range. Using a pressure beyond this range may cause damage.

▼ Since static charge can damage the pressure sensor chip, bear in mind the following handling precautions.

When storing the pressure sensor chips, use a conductive material to short the pins or wrap the entire chip in aluminum foil. Plastic containers should not be used to store or transport the chips since they readily become charged.

When using the pressure sensor chips, all the charged articles on the bench surface and the work personnel should be grounded so that any ambient static will be safely discharged.

▼ Based on the pressure involved, give due consideration to the securing of the pressure sensor DIP type and to the securing and selection of the inlet tube.

Any more question, please contact CFSensor (Email: Sales@CFSensor.com)

The listed specifications and dimensions are subject to change without prior notice.

Application Circuit(example)

This pressure sensor(mV output) is usually amplified for final application by means of constant voltage or constant current.

The right circuit is a typical circuit application in where the pressure sensor is applied by constant current excitation

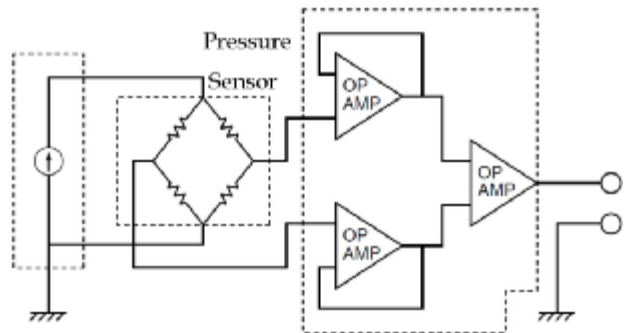

Mounting Ways

The following steps is for transmitting the air pressure to sensor.

- 1,Select the air pressure inlet pipe that is firm enough to prevent the pressure leaks.
- 2,Fix the air pressure inlet pipe securely by a O-ring when pressure is exceed 200kPa.
- 3,Do not block the inlet pipe
- 4,Available for DIP&SOP sensor

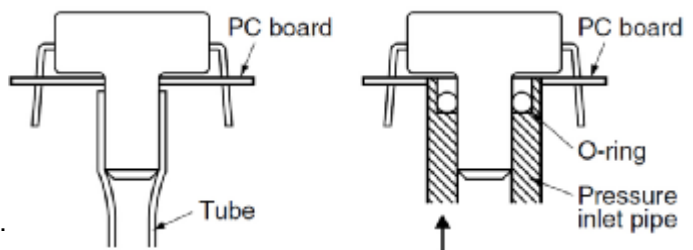

If a tube is used as the pressure inlet pipe, it may become disengaged. Therefore, use a sturdy tube and secure it using O-rings.